

**NEO**

**Gross Power**  
100 HP (74.5 kW) / 2,200 rpm

**Net Power**  
95 HP (71 kW) / 2,200 rpm

**Bucket Capacity**  
Backhoe 0.1 ~ 0.3 m<sup>3</sup>  
Loader 0.1 ~ 0.3 m<sup>3</sup>

**Operating Weight**  
7,440 kg (16,402 lb)

# H940c

With Tier II / Stage II Engine installed



## ▲ HYUNDAI CONSTRUCTION EQUIPMENT

**Head Office(Sales Office)**

3F, Bundang First Tower, 55 Bundang-ro, Bundang-gu, Seongnam-si, Gyeonggi-do, 13591, Korea

**Americas Operation : Hyundai Construction Equipment Americas, Inc.**

6100 Atlantic Boulevard Norcross Ga 30071 U.S.A  
TEL (1) 847-678-823-7802 FAX (1) 847-678-823-7778

**Europe Operation : Hyundai Construction Equipment Europe N.V.**

Hyundailaan 4,  
3980 Tessenderlo, Belgium  
TEL (32) 14-56-2200 FAX (32) 14-59-3405

PLEASE CONTACT



# PRIDE AT WORK

# H940c

Hyundai Construction Equipment strives to build state-of-the-art earthmoving equipment to give every operator maximum performance, more precision, versatile machine preferences, and proven quality. Take pride in your work with a Hyundai!

## POWERFUL AND RELIABLE ENGINE

- Perkins Mechanical engine, with EPA Tier II and E.U. stage II emission regulations, built for power, reliability and efficiency.

## COMFORTABLE OPERATION

- Six pillared cab with ROPS / FOPS certified design for safe operation.
- Tilting, adjustable steering column.
- Hinged-type side windows for excellent ventilation.
- Conveniently located gauges, switches and levers for quick and easy use.
- Suspension seat with full adjustment for improved operator ride.

## EXCELLENT BACKHOE PERFORMANCE

- Pilot controls provide the operator with better precision and control. **Option**
- An extendable dipper significantly increases the machine's versatility. **Option**
- Unique backhoe boom design provides good visibility.

## EXCELLENT VISIBILITY

- One piece rounded wind shield for wide span of view.
- Well designed loader frame offers clear line of site and excellent visibility.

## SERVICEABILITY

- Tilt-up hood provides easy access to engine compartment.
- All greasing points are accessible from ground level for safety and reduced maintenance time.
- Integrated safety bar and lock system ensures operator safety.

## POWERFUL LOADER PERFORMANCE

- Four wheel drive system designed for on-the-go activation improves loader performance in rough terrain conditions. **Option**
- A strong and rigid loader frame designed for durability and greater lifting capacity.
- Automatic return-to-dig function reduces loading cycle times.

## ENHANCED HYDRAULIC MECHANISM

- Adjustable flow control system (AFCS) optimizes the travel power of the machine when traveling on the highway.
- Alternative pilot control pattern allows the operator to get the job done efficiently.
- Stabilizer safety system protects from both raises and lowers of the stabilizer.



\* Photo may include optional equipment.



### Powerful and Reliable Engine

A powerful Perkins Mechanical engine with EPA Tier II and E.U. stage II emissions compliance, 4 cylinder, 4 cycle, turbo-charged, is built for power, reliability, efficiency.

### Axle and Brakes

Front & rear axles are designed for heavy duty to withstand the challenging Jobsite conditions. Outboard, planetary gears improve serviceability while multi wet disc type brakes eliminate possible external contamination.

The parking brake can be easily activated from within the cab by the push of an electric switch.



### Excellent Backhoe Performance

The backhoe is inherently strong design, perfect for heavy duty applications. The boom allows good visibility into the trench when the operator is digging around buried obstructions such as water mains, sewer pipes, utility lines, etc.

Pilot controls(option) improve operator control and precision when excavating. And an extendable dipper as an option significantly increases the machine's versatility.



### Work Lights

Standard two front & two rear-adjustable 55 watt halogen work lights and optional four front & four rear-adjustable 55 watt halogen work lights provide excellent illumination at the work area.

### Four Wheel Drive Option

Four wheel drive system improves mobility and loader performance in ground conditions underfoot and can be activated on-the-go.



### Ride Control System Option

Ride control system is available for improved operator comfort. Ride control reduces bounce and shock when traveling on the job site.

The system is designed to minimize loader lift bounce when traveling over rough terrain to reduce material spillage and improve travel with a full bucket. The operator can engage ride control by flipping the switch on the side console. Ride control improves job site productivity, operator comfort and overall safety.

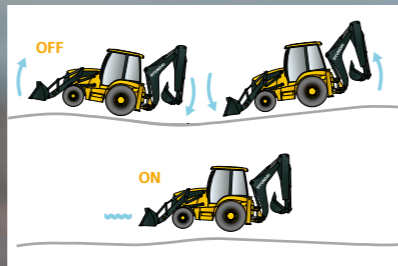

### Powerful Loader Performance

The H940C series loader boom is integrally welded with a large diameter tube, dual lift and tilt cylinders for maximum strength and power. A strong and rigid loader frame allows for greater lift capacity, improved line of site and overall visibility.

The loader attachment can be equipped with automatic return to dig function as an option designed to reduce loading cycle times.



# OUTSTANDING PERFORMANCE

H940C series provides the operator with best performance and productivity.



\* Photo may include optional equipment.

### Clam Safety System **Option**

Prevents the uncontrolled opening of the clam bucket by its weight of load during both loading and dozing processes.



### Control Pattern Selector **Option**

The control pattern selector switch, located in the cabin, allows the operator to change from the excavator ISO control pattern to the backhoe SAE control pattern (Hyundai A type) for the backhoe simply by pressing a button. This allows the operator to use the accustomed pattern they are familiar with to get the job done efficiently.

### Stabilizer Safety System

Two stabilizers and two stabilizer safety valves are equipped (each operated by its own control valve and cylinder). Provides protection in the event of a hose burst in both stabilizers. Protects from both raises (while working) and lowers (while traveling) of the stabilizer.



### Adjustable Flow Control System [AFCS]

By using the "turtle" switch ("turtle" for low speed attachment control) on the front instrument cluster, the operator diverts any unused hydraulic fluid from the second pump to the hydraulic reservoir. In a loader application, AFCS optimizes the travel power of the machine and improves productivity. AFCS is also useful when traveling on the road.



# ENHANCED HYDRAULIC MECHANISM

Innovative hydraulic technologies make the H940C series fast, smooth and easy to control.



## Comfortable Operator's Cab

The H940C series cab is designed to offer maximum comfort, safety and low noise to the operator. The cab structure is supported by six pillars meeting ROPS/FOPS safety requirements. The cab also offers dual entry, deluxe trim, tilt steering column and a washable molded floor mat. Large roomy cab space and rounded glass contribute to operator comfort. Adjustable seat for a wider operating range and more comfortable ride. Equipped with seat cushion extension, seat cushion tilt, and vertical angle adjusting armrests.

## Climate Control System Option

A full heating, defrosting system keeps the operator comfortable with 15 air vents placed throughout the cab. Air conditioning system as an option well placed air vents within front, back and sides of seat provides operator with optimum temperature.



## Pilot control safety system Option

Disables the control lever of loader, backhoe (excavator), and stabilizer levers by flipping the safety switch on the side console



Safety Switch  
(loader)



Safety Switch  
(backhoe)

## Power Boosted Brake Option

Newly developed Boosted Brake System now allows the operator to use brake much conveniently with additional hydraulic assisted power.



## Brakes

Oil immersed wet disc brakes are individually actuated by two separated brake pedals. Brakes are self adjusting for improved service life.

## Power Shift Transmission

Standard power shift transmission provides fast, easy and efficient operation. A convenient gear/shift selector allows for gear selection and forward, neutral or reverse direction.



## Excellent Visibility

One-piece rounded front glass and large windows around the cab provide the operator with a full 360 degree range of visibility. Wide upper front window good visibility to cutting edge of bucket for loader. Sloped and narrow bonnet is designed for easy and safe work with the front loader.

## Side Console with Full Instrumentation

In the H940C series cab, all gauges switches and levers are conveniently located for easy access. Whether in the loader position or the backhoe position, the operator can easily reach all controls.



# COMFORTABLE OPERATION

H940C series backhoe loaders are designed for the operator's comfort. The steering column and backhoe control tower can be tilted and adjusted for convenient operation. Deluxe, joystick levers, conveniently located switches and an AM/FM radio with mp3 input provide the pleasant operation. Hinge-type side windows can be opened for improved ventilation. Additionally, front and rear windshield wipers are equipped for excellent visibility during bad weather conditions.



# SERVICEABILITY

## Quick and Easy Maintenance

Tilt-up hood provides easy access to the engine compartment. The one-piece hood tilts away for easy ground access to all critical services and grease points for maintenance and operator safety.

## Integrated Safety Bar

An integrated safety bar and locking pin are an integral part of the bucket cylinder, and guarantee operator safety when servicing.



## Visible Hydraulic Oil Level Gauge

The hydraulic oil sight gauge is installed on the side of the hydraulic tank for the convenient inspection from on ground level.



# SPECIFICATIONS

ENGINE		
Maker / Model	Perkins / 1104C-44T	
Type	4-stroke, water cooled turbocharged.	
Non-road emission standards	Certified to EPA Tier II / EU stage II	
Displacement	4.4 l	
Fuel	Diesel	
Horsepower	Gross	100 hp (74.5 kW) @ 2,200 rpm
	Net	95 hp (71 kW) @ 2,200 rpm
Maximum torque	42 kg-m @ 1,350 rpm	

HYDRAULIC SYSTEM	
System type	Open center
Pump type	Tandem gear pump
Pump flow	138.4 L/min (Steering + Attachment)
System Pressure	250 kg/cm <sup>2</sup>
Loader valve	- Mechanical control (Standard) : 1 Lever - Pilot control (Option) : 1 Joystick, Boom float, Bucket return to dig
Backhoe valve	- Mechanical control (Standard) : 2 Levers - Pilot control (Option) : 2 Joysticks Pilot control (Excavator ISO control pattern is standard) Optional pattern change valve for excavator (ISO) control pattern ↔ Backhoe (SAE) control pattern
Stabilizer Control	- Mechanical Control (Standard) : 2 Levers - Pilot Control (Option) : 2 small levers - Stabilizer Safety lock valve (Standard)

ELECTRICAL	
Voltage	12 volts
Alternator	100 amp
Battery	850 CCA (Standard) = 1EA

OPERATING WEIGHTS		
Standard configuration	2WD, GP bucket (0.8m <sup>3</sup> ), counter weight (350kg), ROPS/FOPS canopy, mono dipper	7,440 kg
Optional configuration	4WD, MP bucket (1.0m <sup>3</sup> ), counter weight (150kg), ROPS/FOPS cabin, ext. dipper	8,230 kg
Add-on weight	Counter weight	550 kg
	Drive shaft & T/M under guard	55 kg
	Fork	170 kg

TIRES		
Front	STD	11L-16SL,12PR (2WD)
	OPT	12.5/80-18,12PR (4WD)
Rear	STD	19.5-24,12PR
	OPT	16.9-28,12PR

SERVICE REFILL CAPACITIES	
Fuel tank	127 l
Engine coolant water	19 l
Engine oil with filter	8 l
Hyd. tank with filter	50 l
Hyd. system total	93 l
Transmission and torque converter	18 l
Front axle (4WD)	8 l
Rear axle	16 l

BACKHOE ATTACHMENTS	
Buckets	0.2m <sup>3</sup> (STD)
	0.17m <sup>3</sup>
	0.26m <sup>3</sup>
Boom	2.63m (STD) 2.81m
Arm	2.0m (STD) 2.0m ~ 3.12m

LOADER BUCKETS			
Capacity	Remark	Capacity	Remark
0.8 m <sup>3</sup>	GP BOCE (STD)	0.9 m <sup>3</sup>	GP Tooth
1.0 m <sup>3</sup>	GP BOCE	1.0 m <sup>3</sup>	MP
0.7 m <sup>3</sup>	GP Tooth	1.0 m <sup>3</sup>	MP with Fork

\*GP : General Purpose, MP : Multi Purpose  
\*BOCE : Bolt on Cutting Edge

COUNTER WEIGHT	
Description	Weight
None, Guard Front	10 kg
Casting, Additional	150 kg
Casting (STD)	350 kg
Casting Additional for Telescopic Arm	550 kg

POWERTRAIN				
Transmission	4-speed helical-cut gears, full powershift standard; electric clutch cutoff on loader lever			
Maximum travel speed with standard tire				
H940C	Gear 1	Gear 2	Gear 3	Gear 4
Forward (km/hr)	5.2	9.6	19.4	34.0
Reverse (km/hr) (Option)	6.6	12.0	(19.0)	N/A
Torque converter	Single stage, dual phase			
Differential	Hydraulic locking rear Push-button activation			
Steering (Option)	Hydrostatic power (emergency steering)			
Brake	Service	Power assisted, hydraulic wet disc, mounted inboard, self-adjusting and self-equalizing		
	Parking	Spring-applied, hydraulically releases, wet, multi disc independent of service brakes with electric switch control		

# DIMENSIONS & WORKING RANGE

## DIMENSIONS

All dimensions are approximate.

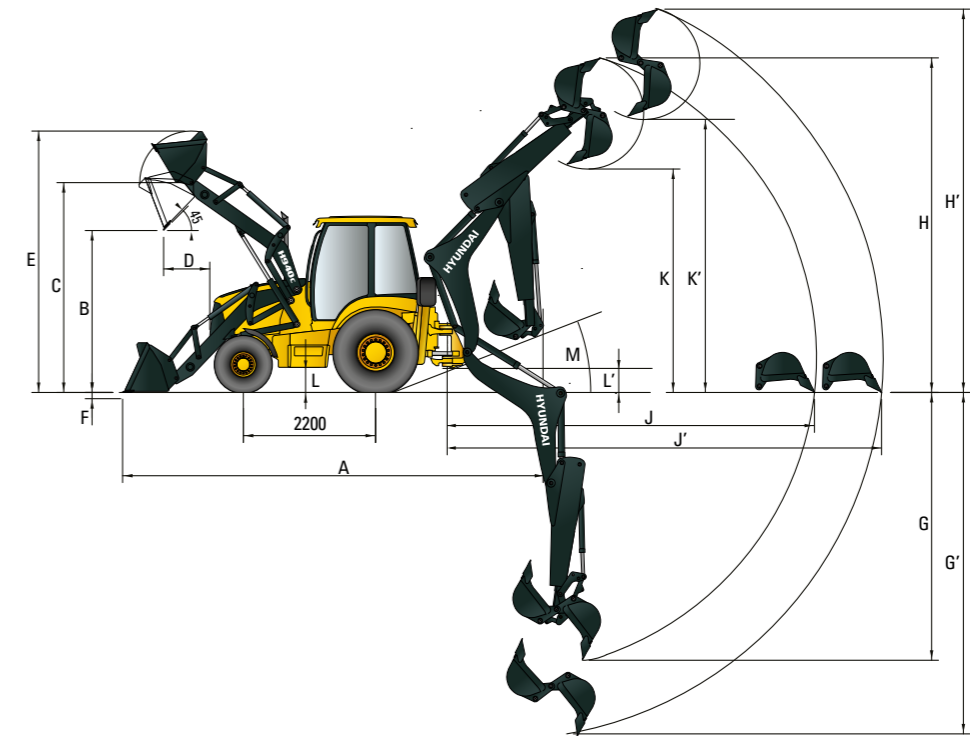

Unit : mm (ft-in)

DESCRIPTION	
A	Overall length 7,080 (23' 3")
B	Dump clearance 2,710 (8' 11")
C	Hinge pin height 3,450 (11' 4")
D	Dump reach 805 (2' 8")
E	Max loading height 4,230 (13' 11")
F	Depth of bucket down 96 (0' 4")
G	Max digging depth (STD) 4,345 (14' 3")
G'	Max digging depth (EXT) 5,460 (17' 11")

DESCRIPTION	
H	Max digging height (STD) 5,500 (18' 1")
H'	Max digging height (EXT) 6,150 (20' 2")
J	Max digging reach (STD) 5,830 (19' 2")
J'	Max digging reach (EXT) 6,860 (22' 6")
K	Max dumping height (STD) 3,585 (11' 9")
K'	Max dumping height (EXT) 4,230 (13' 11")
L	Minimum ground clearance 355 (1' 2")
L'	Height of outrigger 355 (1' 2")
M	Departure angle 19°

BUCKETS		
	GP Bucket	MP Bucket
Transport length	7,080 (23' 3")	7,210 (23' 8")
Transport height	3,680 (12' 1")	3,680 (12' 5")
Transport width	2,250 (7' 5")	2,300 (7' 7")

# STANDARD / OPTION

# MEMO

ENGINE	STD	OPT
Perkins 1104C-44T	●	
<b>HYDRAULIC SYSTEM</b>		
Backhoe controls, 2-lever mechanical	●	
Loader controls, 1-lever mechanical	●	
Stabilizer controls, 2-lever mechanical	●	
Fan, suction	●	
Hydraulic hose face seals, o-ring	●	
Hydraulic oil cooler, T/M cooler	●	
Hydraulic valves, loader 3rd Function		●
Hydraulic valves, backhoe 7th Function		●
Hydraulic lines		●
One-way, backhoe breaker line		●
Pilot control (Backhoe, Loader, Stabilizers all together)		●
<b>CAB &amp; INTERIOR</b>		
Air cleaner	●	
Alarm, back-up	●	
Radio		●
Coolant/Antifreeze	●	
Floor mat	●	
Gauges : coolant temperature, fuel level, tachometer, hour meter	●	
Indicators: Engine oil pressure, T/M oil temp, diff. lock, coolant temp, fuel level, battery charge, air cleaner, high beam, parking	●	
Instrument panel lights	●	
Seat belt, retractable (51 mm / 2 in)	●	
Seat, suspension with armrest	●	
Storage compartment, internal	●	
Throttles, hand and foot	●	
Transmission neutralizer button switch	●	
Air conditioner & Heater		●
Air conditioner only		●
Fuel warmer		●
Speed meter		●
Climate control system		●
Cabin ROPS / FOPS		●
Canopy ROPS / FOPS	●	
Canopy ROPS / FOPS with front shield		●
<b>SAFETY</b>		
Differential lock	●	
Brakes, oil disc, dual pedals, interlocking	●	
Flashing hazard/signal lights	●	
Working lights (2 front, 2 rear)	●	
Machine security system	●	
Mirror, rear view	●	
Parking brake	●	
Stop and tail lights	●	
Swing transport lock	●	
Warning horn, electric	●	
Grill guard bumper		●
Front drive shaft guards		●
Work lights(4 front, 4 rear)		●
Rotating beacon		●
Power boosted brake		●
Pilot control safety system		●
Clam safety system		●

ATTACHMENT	STD	OPT
Stabilizers (Pad for street)		●
<b>Backhoe</b>		
Buckets		
0.2 m <sup>3</sup> (0.26 yd <sup>3</sup> )	●	
0.17 m <sup>3</sup> (0.22 yd <sup>3</sup> )		●
0.26 m <sup>3</sup> (0.34 yd <sup>3</sup> )		●
Boom		
2.63 m for Heavy duty	●	
2.63 m		●
2.81 m		●
Dipper		
2.00 m ~3.12 m (Telescopic)		●
2.00 m	●	
<b>Front loader</b>		
General purpose buckets		
0.8 m <sup>3</sup> (1.04 yd <sup>3</sup> ) - Bolt-on cutting edge	●	
0.7 m <sup>3</sup> (0.92 yd <sup>3</sup> ) - Bolt-on teeth		●
0.9 m <sup>3</sup> (1.18 yd <sup>3</sup> ) - Bolt-on teeth		●
1.0 m <sup>3</sup> (1.31 yd <sup>3</sup> ) - Bolt-on cutting edge		●
Multi purpose buckets		
1.0 m <sup>3</sup> (1.3 yd <sup>3</sup> )		●
1.0 m <sup>3</sup> (1.3 yd <sup>3</sup> ) w/ forks		●
<b>OTHER</b>		
Battery, maintenance-free, 850 CCA x 1	●	
Battery, maintenance-free, 630 CCA x 2		●
Battery disconnect switch	●	
Filters, spin-on	●	
Fuel prefilter with water separator	●	
Glow plug (cold starting aid)	●	
Ground level fuel fill	●	
Power receptacle, 12V	●	
Power steering, hydrostatic	●	
Emergency steering		●
Toolbox, external, lockable	●	
Torque converter	●	
Transmission : Power shift, 4 forward, 2 reverse, 2 wheel drive	●	
Transmission : Power shift, 4 forward, 3 reverse, 4 wheel drive		●
Boom transport lock - Backhoe (Cylinder)	●	
Boom locking bar - Loader	●	
Mechanical quick coupler		●
Swing damper		●
Counter weights		
Guard front, 10 kg (22 lb)	●	
Casting, 150 kg (331 lb)		●
Casting, 350 kg (772 lb)		●
Casting additional for telescopic arm, 550 kg (1213 lb)		●
Return-to-dig, loader		●
Ride control, loader		●
Control pattern selector		●
<b>UNDERCARRIAGE</b>		
Fenders, rear	●	
Tilt steering wheel	●	
Tire(Front) : 11L-16SL,12PR(2WD, ATG)	●	
Tire(Rear) : 19.5-24,12PR(ATG)	●	
Fenders, 4WD, front		●
Tire(Front) : 12.5/80-18,12PR(4WD, ATG)		●
Tire(Rear) : 16.9-28,12PR(ATG)		●

\* Standard and optional equipment may vary. Contact your Hyundai dealer for more information. The machine may vary according to International standards.

\* The photos may include attachments and optional equipment that are not available in your area.

\* Materials and specifications are subject to change without advance notice.

\* All imperial measurements rounded off to the nearest pound or inch.