

STANDARD EQUIPMENT

ISO Standard cabin
All-weather steel cab with 360° visibility
Safety glass windows
Rise-up type windshield wiper
Sliding fold-in front window
Sliding side window(LH)
Lockable door
Hot & cool box
Storage compartment & Ashtray
Cabin roof cover transparent
Radio & USB player
12 volt power outlet (24V DC to 12V DC converter)
Handsfree mobile phone system with USB
Sun visor
Air-suspension seat with heater
Cabin FOPS/FOG (ISO/DIS 10262 Level II)
FOPS (Falling Object Protective Structure)
FOG (Falling Object Guard)
Cabin lights
Computer aided power optimization (New CAPO) system
3-power mode, 2-work mode, User mode
Auto deceleration & one-touch deceleration system
Auto warm-up system
Auto overheat prevention system
Automatic climate control
Full automatic temperature control
Defroster
Self-diagnostics system
Starting Aid (air grid heater) for cold weather
Centralized monitoring
LCD display
Engine speed or Trip meter/Accel.
Clock
Gauges
Fuel level gauge
Engine coolant temperature gauge
Hyd. oil temperature gauge
Warnings
Check engine
Overload
Communication error
Low battery
Air cleaner clogging
Indicators
Max power
Low speed/High speed
Fuel warmer
Auto idle
Three outside rearview mirrors
Fully adjustable suspension seat with seat belt
Console box height adjust system
Six front working lights, two rear lights
Air horn
Batteries (4 x 12V x 160 AH)
Battery master switch
Removable clean-out dust net for cooler
Automatic swing brake
Automatic fuel line deaeration
Fuel pre-filter with fuel warmer
Boom holding system
Arm holding system
Track shoes (700mm, 27.6")
Full track rail guard
Accumulator for lowering work equipment
Electric transducer
Lower frame under cover
Travel alarm

OPTIONAL EQUIPMENT

Fuel filler pump (50 L/min)
Beacon lamp
Booms
8.05m, 26' 5"
8.2m, 26' 11"
10.5m, 34' 5"
11.3m, 37' 1"
Arms
3.4m, 11' 2"
3.6m, 11' 8"
6.5m, 21' 4"
8.0m, 26' 3"
Track shoes
Double grouser shoe (800mm, 32")
Double grouser shoe (900mm, 35")
Pre-heating system, coolant (16kw)
Tool kit
Operator suit
Rearview camera
Seat
Mechanical suspension seat
Mechanical suspension seat with heater
Air-suspension seat with heater
Automatic lubrication
Hi-mate (Remote Management System)
Safety lock valve for boom cylinder
Safety lock valve for arm cylinder
Single- acting piping kit
Double- acting piping kit
Quick coupler
Cabin roof-steel cover
Heavy duty aircleaner

- * Standard and optional equipment may vary. Contact your Hyundai dealer for more information. The machine may vary according to International standards.
- * The photos may include attachments and optional equipment that are not available in your area.
- * Materials and specifications are subject to change without advance notice.
- * All imperial measurements rounded off to the nearest pound or inch.

Robex 850LC-9

With Tier 3 Engine installed



*Photo may include optional equipment

Pride at Work

Hyundai Construction Equipment strives to build state-of-the-art earthmoving equipment to give every operator maximum performance, more precision, versatile machine preferences, and proven quality. Take pride in your work with Hyundai!

Robex 850LC-9

Machine Walk-Around

Engine Technology

Proven / reliable, fuel efficient Cummins Tier III QSX15 Engine.
Electronically controlled for optimum fuel to air ratio and clean, efficient combustion.
Low noise / Auto engine overheat feature / Anti-restart feature.

Hydraulic System Improvements

New patented hydraulic control for improved controllability / Improved control valve design for added efficiency and smoother operation / New auto boom and swing priority system for optimum speed / New auto power boost feature for additional power when needed / Improved arm-in and boom-down flow regeneration system for added speed and efficiency.
9 Series reduced fuel consumption by 4% compared with 7A series.

Pump Compartment

Industry-leading, powerful, reliable Kawasaki designed, variable volume in-line axial piston pumps.
New compact solenoid block equipped with 4 solenoid valves, 1 EPPR valves, 1 check valve accumulator and pilot filter - controls 2 speed travel, power boost, boom priority, safety lock.

Enhanced Operator Cab

Improved Visibility

Enlarged cab with improved visibility / See-through upper skylight for visibility and ventilation
Larger right-side glass, now one piece, for better right visibility.
Safety glass windows on all sides - less expensive than (polycarbonate) and won't scratch or fade.
Closeable sunshade for operator convenience / Reduced front window seam for improved operator view.

Improved Cab Construction

New steel tube construction for added operator safety, protection and durability.
New window open/close mechanism designed with cable and spring lift assist and single latch release.

Improved Suspension Seat / Console Assembly

Ergonomic joysticks with auxiliary control buttons for attachment use. Now with new sleek styling.
Heated suspension (standard) or optional air ride suspension with heat.
New joystick consoles - now adjustable in height by way of dial at bottom.
Adjustable arm rests - turn dial to raise or lower for optimum comfort.

Advanced 7" Color Cluster

New Color LCD Display with easy to read digital gauges for hydraulic oil temperature, water temperature and fuel. Simplified design makes adjustment and diagnostics easier.
Also, new enhanced features such as rear-view camera are integrated into monitor.
3 power modes : (P) Power, (S) Standard, (E) Economy, and (U) User mode for operator preference.
Enhanced self-diagnostic features with GPS download capability.
New anti-theft system with password capability.
Boom speed and arm regeneration are selectable through the monitor.
Auto power boost is now available - selectable (on/off) through the monitor.
Powerful air conditioning and heat with auto climate control, 20% more heat and air output than 7A series!

RMS

RMS (Remote Management System) works through GPS/satellite technology to ultimately provide better customer service and support.

Undercarriage

Sealed track chain (urethane seals) / Optional full track rail guard / Comfortable bolt-on steps.
Large upper roller cut-outs for debris clean-out / Tapered side frames for debris clean-out / Grease-type track tensioner.



*Photo may include optional equipment.

Preference

Operating a 9 series is unique to every operator. Operators can fully customize their work environment and operating preferences to fit their individual needs.



*Photo may include optional equipment.



Wide Cabin with Excellent Visibility

The newly designed cabin was conceived for more space, a wider field of view and operator comfort. Single piece right side glass improves visibility and operator comfort. Plus, the front defrosting system provides more comfortable working condition. Special attention was given to a clear, open and convenient interior with plenty of visibility on the machine surroundings and the job at hand. This well balanced combination of precision aspects put the operator in the perfect position to work safely and securely.

Operator Comfort

In 9 series cabin you can easily adjust the seat, console and armrest settings to best suit your preferred comfort level. Other preference settings that add to overall operator comfort include the full automatic high capacity air conditioning system, transparent polycarbonate glass sun roof, large and easy to control sun visor, and radio / USB player.



Reduced Stress

Work is stressful enough. Your work environment should be stress free. Hyundai's 9 series provides improved cab amenities, additional space and a comfortable seat to minimize stress to the operator. The powerful climate control system and the optimized vent positions provide the operator with optimum air temperature. An advanced audio system with USB player, AM/FM stereo, plus remotely located controls is perfect for listening to music favorites. Operators can even talk on the phone with the hands-free cell phone feature.



Operator - Friendly Cluster

The advanced new cluster with 7 inch wide color LCD screen and toggle switch allows the operator to select his personal machine preferences. Power and work mode selection, self diagnostics, optional rear-view camera, maintenance check lists, start-up machine security, and video functions were integrated into the cluster to make the machine more versatile and the operator more productive.



Precision

Innovative hydraulic system technologies make the 9 series excavator fast, smooth and easy to control.



*Photo may include optional equipment.

Computer Aided Power

The engine horsepower and hydraulic horsepower together in unison through the advanced CAPO(Computer Aided Power Optimization) system, flow for the job at hand. Operator can set their own preferences for boom or swing priority, power mode selection and optional work tools at the touch of a button.

The CAPO system also provides complete self diagnostic features and digital gauges for important information like hydraulic oil temperature, water temperatures and fuel level. This system interfaces with multiple sensors placed throughout the hydraulic system as well as the electronically controlled engine to provide the optimum level of engine power and hydraulic flow.

Power Mode

P (Power Max) mode maximizes machine speed and power for mass production. **S (Standard) mode** provides a reduced, fixed rpm for optimum performance and improved fuel economy. For maximum fuel savings and improved control, **E (Economy) mode** provides precise flow and engine power based on load demand. Three unique power modes provide the operator with custom power, speed and fuel economy.

User Mode

Some jobs require more precise machine settings. Using the versatile **U (User) mode**, the operator can customize engine speed, pump output, idle speed and other machine settings for the job at hand.

Improved Hydraulic System



To achieve optimum precision, Hyundai redesigned the hydraulic system to provide the operator with super fine touch and improved controllability. Improved pump flow control reduces flow when controls are not being used to minimize fuel consumption.

Improved spool valves in the control valve are engineered to provide more precise flow to each function with less effort.

Improved hydraulic valves, precision-designed variable volume piston pumps, fine-touch pilot controls, and enhanced travel functions make any

operator running a 9 series look like a smooth operator. Newly improved features include arm-in and boom-down flow regeneration, improved control valve technology and innovative auto boom and swing priority for optimal performance in any application.



Auto Boom-swing Priority

This smart function automatically and continuously looks the ideal hydraulic flow balance for the boom and swing motions of the machine. The advanced CAPO system monitors the hydraulic system and adjusts its settings to maximize performance and productivity.

Performance

9 series is designed for maximum performance to keep the operator working productively.



*Photo may include optional equipment.

Excellent Reliability and Durability

Durable track rail guards keep track links in place. Track adjustment is made easy with standard grease cylinder track adjusters and shock absorbing springs. The strengthened undercarriage is designed for excellent production at quarries and mines. R850LC-9 is equipped with covers to protect the travel motors and hoses against damage from rocks.

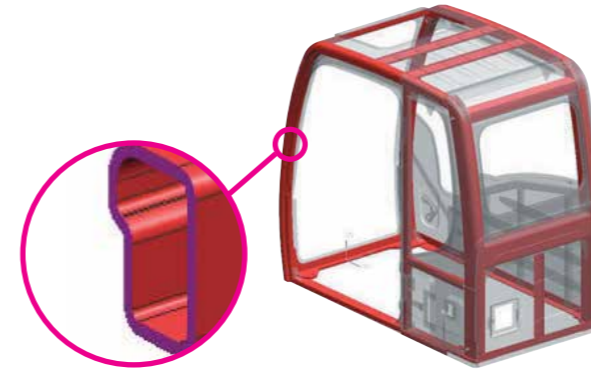

Structure Strength

The 9 series cabin structure has been fitted with stronger but slimmer tubing for more safety and improved visibility. Low-stress, high strength steel is integrally welded to form a stronger, more durable upper and lower frame. Structural integrity was tested by way of FEM (Finite Elements Method) analysis and long-term durability tests.

CUMMINS QSX15 Engine

The six cylinders, turbocharged, 4 cycle, charger air cooled engine is built for power, reliability, economy and low emissions. This engine meets Tier III emissions regulations.

Heavy-duty strength

The QSX15 features dual overhead cams for superior performance. The first cam drives up to 30,000 psi (2,000 bar) of fuel injection for cleaner, more powerful combustion. The second cam operates the intake and exhaust valves, with a separate set of lobes specifically designed to operate the optional interbrake,™ capable of up to 400hp (298kW). Improved power cylinder components provide up to 40% longer life before cylinder wear out. A patented wastegated turbo with variable step settings delivers maximum performance without over boost at high speeds and increased airflow at lower speed for improved responsiveness.



Profitability

9 series is designed to maximize profitability through improved efficiencies, enhanced service features and longer life components.



*Photo may include optional equipment.

Easy Access

Concentrated engine filters, remote type fuel pre-filter and fuel cut valve, and wide open compartments make service more convenient. The auto greasing system at the touch of a button provides simple and easy maintenance.



Hi-mate (Remote Management System)

Hi-mate, Hyundai's proprietary remote management system, provides operators and dealer service personnel access to vital service and diagnostic information on the machine from any computer with internet access. Users can pinpoint machine location using digital mapping and set machine work boundaries, reducing the need for multiple service calls. Hi-mate saves time and money for the owner and dealer by promoting preventative maintenance and reducing machine downtime.

Enhanced Safety

Variable cabin guards offers enhanced operator safety. And the work lamps on the cab improved operator convenience at night time. Wide cat-walks, large handrails and anti-slip plates provide easy access to the cab and safer maintenance.



Long-Life Components

9 series excavators were designed with bushings designed for long-life lube intervals (250hrs) & polymer shims (wear resistant, noise reducing), long-life hydraulic filters (1,000hrs), long-life hydraulic oil (5,000hrs), more efficient cooling systems and integrated preheating systems which extend service intervals, minimize operating costs and reduce machine down time.

Specifications

ENGINE

MODEL		CUMMINS QSX15	
Type		Water-cooled, 4-cycle Diesel, 6-Cylinder in-line, Direct injection, Turbocharged, Charger air cooled, Low emission	
Rated flywheel horsepower	SAE	J1995 (gross) J1349 (net)	510HP (380kW) / 1,800rpm 490HP (366kW) / 1,800rpm
	DIN	6271/1 (gross) 6271/1 (net)	517PS (380kW) / 1,800rpm 497PS (366kW) / 1,800rpm
Max. torque		241.1kgf·m (1,744lb·ft) / 1,400rpm	
Bore X stroke		137mm X 169mm (5.39" X 6.65")	
Piston displacement		15,000cc (915 in ³)	
Batteries		4 X 12V X 160AH	
Starting motor		24V, 9.0kW	
Alternator		24V, 100Amp	

HYDRAULIC SYSTEM

MAIN PUMP	
Type	Variable displacement axis piston pumps
Max. flow	2 X 504 L/min (133.1 US gpm / 110.9 UK gpm)
Sub-pump for pilot circuit	Gear pump

Cross-sensing and fuel saving pump system

HYDRAULIC MOTORS	
Travel	Two-speed axial pistons motor with brake valve and parking brake
Swing	Axial piston motor with automatic brake

RELIEF VALVE SETTING	
Implement circuits	330 kgf/cm ² (4,690 psi)
Travel	330 kgf/cm ² (4,693 psi)
Power boost (boom, arm, bucket)	360 kgf/cm ² (5,120 psi)
Swing circuit	290 kgf/cm ² (4,120 psi)
Pilot circuit	40 kgf/cm ² (569 psi)
Service valve	Installed

HYDRAULIC CYLINDERS	
No. of cylinder bore X stroke	Boom : 2-200 x 1,892 mm
	Arm : 1-215 x 2,250 mm
	Bucket (A) : 1-200 x 1,593 mm
	Bucket (B) : 1-215 x 1,593 mm Bucket (C) : 1-170 x 1,370mm

*Bucket (A) : Boom (8,050mm/8,200mm) + Arm (3,400mm/3,600mm)
Bucket (B) : Boom (7,200mm) + Arm (2,950mm)
Bucket (C) : Boom (10,500mm/11,300mm) + Arm (6,500mm/8,000mm)

DRIVES & BRAKES

Drive method	Fully hydrostatic type
Drive motor	Axial piston motor, in-shoe design
Reduction system	Planetary reduction gear
Max. drawbar pull	59,300 kgf (130,730 lbf)
Max. travel speed (high / low)	3.8 km/hr (2.4 mph) / 2.7 km/hr (1.7 mph)
Gradeability	35° (70 %)
Parking brake	Multi wet disc

CONTROL

Pilot pressure operated joysticks and pedals with detachable lever provide almost effortless and fatigueless operation.

Pilot control	Two joysticks with one safety lever (LH): Swing and arm, (RH): Boom and bucket (ISO)
Traveling and steering	Two levers with pedals
Engine throttle	Electric, Dial type

SWING SYSTEM

Swing motor	Axial piston motor
Swing reduction	Planetary gear reduction
Swing bearing lubrication	Grease-bathed
Swing brake	Multi wet disc
Swing speed	6.2 rpm

COOLANT & LUBRICANT CAPACITY

Re-filling	liter	US gal	UK gal
Fuel tank	940.0	248.0	206.0
Engine coolant	65	17.2	14.3
Engine oil	43.5	11.5	9.5
Swing device - gear oil	8.0	2.1	1.8
Final drive (each) - gear oil	20.0	5.3	2.4
Hydraulic system (including tank)	800.0	211.0	175.6
Hydraulic tank	450.0	119.0	99.0

UNDERCARRIAGE

The X-leg type center frame is integrally welded with reinforced box-section track frames. The undercarriage includes lubricated rollers, idlers, track adjusters with shock absorbing springs and sprockets, and a track chain with double or triple grouser shoes.

Center frame	X-leg type
Track frame	Tetragonal box type
No. of shoes on each side	51
No. of carrier rollers on each side	3
No. of track rollers on each side	9
No. of full track guard on each side	1

OPERATING WEIGHT (APPROXIMATE)

Operating weight, including 7,200mm (23' 7") boom, 2,950mm (9' 8") arm, SAE heaped 4.04m³(5.28yd³) HD bucket, lubricant, coolant, full fuel tank, full hydraulic tank and all standard equipments.

MAJOR COMPONENT WEIGHT	
Upperstructure	52,025kg (114,700lb)
Counterweight	12,600kg (27,560lb)
Boom (with Arm cylinder)	7,765kg (17,120lb)

OPERATING WEIGHT 850LC-9			
Shoes	Operating weight	Ground pressure	
Type	Width mm (in)	kg (lb)	kgf/cm ² (psi)
Double grouser	*700 mm (28")	84,000 (185,190)	1.10 (15.64)
	800 mm (32")	84,810 (186,970)	0.97 (13.79)
	900 mm (35")	85,620 (188,760)	0.87 (12.37)

OPERATING WEIGHT 850LC-9 FS			
Shoes	Operating weight	Ground pressure	
Type	Width mm (in)	kg (lb)	kgf/cm ² (psi)
Double grouser	*700 mm (28")	87,600 (193,120)	1.15 (16.35)
	800 mm (32")	88,410 (194,910)	1.01 (14.36)
	900 mm (35")	89,220 (196,690)	0.91 (12.94)

*Standard equipment

BUCKETS All buckets are welded with high-strength steel.

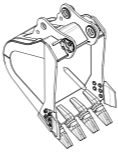
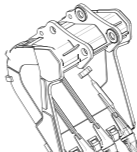
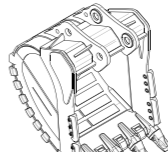
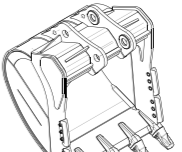
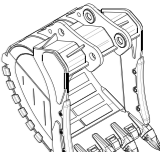
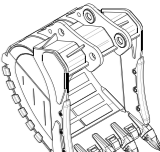
					
SAE heaped m ³ (yd ³)	L/Reach 1.65 (2.16) 2.56 (3.35)	Rock 3.40 (4.45)	Heavy duty 3.40 (4.45) 4.04 (5.28) 4.50 (5.89)	Heavy duty 4.85 (6.34)	Rock 3.40 (4.45) / 4.04 (5.28) 4.25 (5.56) / 4.50 (5.89)

Capacity m ³ (yd ³)	Width mm (in)	Weight kg (lb)	Tooth EA	Recommendation mm (ft-in)				
				7,200 (23' 7") Boom 2,950 (9' 8") Arm	8,050 (26' 5") Boom 3,400 (11' 2") Arm	8,200 (26' 11") Boom 3,400 (11' 2") Arm	10,500 (34' 5") Boom 6,500 (21' 4") Arm	11,300 (37' 1") Boom 8,000 (26' 3") Arm
1.65 (2.16)	1,290 (50.8")	1,520 (3,351)	4	—	—	—	●	■
2.56 (3.35)	1,785 (70.3")	1,870 (4,123)	4	—	—	—	■	—
Ⓜ 3.40 (4.45)	1,741 (68.5")	4,470 (9,855)	4	●	●	■	—	—
Ⓜ 4.04 (5.28)	1,969 (77.5")	4,890 (10,781)	5	●	■	■	—	—
Ⓜ 4.50 (5.89)	2,125 (83.6")	5,120 (11,288)	5	■	■	▲	—	—
Ⓜ 4.85 (6.34)	2,255 (88.8")	5,073 (11,184)	5	■	▲	—	—	—
Ⓜ 3.40 (4.45)	1,700 (66.9")	3,795 (8,366)	4	●	●	●	—	—
Ⓜ 3.40 (4.45)	1,741 (68.5")	4,610 (10,163)	5	●	■	■	—	—
Ⓜ 4.04 (5.28)	1,969 (77.5")	5,020 (11,067)	5	●	■	■	—	—
Ⓜ 4.25 (5.56)	2,040 (80.3")	5,150 (11,350)	5	■	■	▲	—	—
Ⓜ 4.50 (5.89)	2,125 (83.7")	5,250 (11,574)	5	■	■	—	—	—

Ⓜ Heavy duty bucket
Ⓜ Rock bucket

● : Applicable for materials with density of 2,100 kg /m³ (3,500 lb/ yd³) or less
● : Applicable for materials with density of 1,800 kg /m³ (3,000 lb/ yd³) or less
■ : Applicable for materials with density of 1,500 kg /m³ (2,500 lb/ yd³) or less
■ : Applicable for materials with density of 1,200 kg /m³ (2,000 lb/ yd³) or less
▲ : Applicable for materials with density of 900 kg /m³ (1,500 lb/ yd³) or less
— : Not Recommended

ATTACHMENT

Boom and arms are of all-welded, low-stress, full-box section design. 7,200mm(23' 7"), 8,050mm(26' 5"), 8,200mm(26' 11"), 10,500mm(34' 5"), 11,300mm(37' 1")boom and 2,950mm(9' 8"), 3,400mm(11' 2"), 3,600mm(11' 10"), 6,500mm(21' 4"), 8,000mm(26' 3") arms are available. Hyundai Buckets are all-welded, high-strength steel implements.

DIGGING FORCE

Boom	Length	mm (ft-in)	7,200 (23' 7")	8,050 (26' 5")	8,200 (26' 11")	10,500 (34' 5")	11,300 (37' 1")	Remarks
	Weight	kg (lb)	6,370 (14,040)	7,020 (15,480)	7,480 (16,490)	7,300 (16,090)	7,500 (16,530)	
Arm	Length	mm (ft-in)	2,950 (9' 8")	3,400 (11' 2")	3,600 (11' 10")	6,500 (21' 4")	8,000 (26' 3")	
	Weight	kg (lb)	2,910 (6,420)	3,070 (6,770)	3,290 (7,250)	3,600 (7,940)	3,850 (8,490)	
Bucket digging force	SAE	kN	388.3[423.7]	336.4[367.0]	336.4[367.0]	248.0	248.0	
		kgf	39,600[43,200]	34,300[37,420]	34,300[37,420]	25,290	25,290	
		lbf	87,300[95,240]	75,620[82,500]	75,620[82,500]	55,750	55,750	
	ISO	kN	443.3[483.6]	384.4[419.3]	384.4[419.3]	291.1	291.1	
		kgf	45,200[49,310]	39,200[42,760]	39,200[42,760]	29,680	29,680	
		lbf	99,650[108,710]	86,420[94,270]	86,420[94,270]	65,430	65,430	
Arm crowd force	SAE	kN	318.7[347.7]	292.2[318.8]	282.4[308.1]	181.4	153.5	
		kgf	32,500[35,450]	29,800[32,510]	28,800[31,420]	18,500	15,650	
		lbf	71,650[78,150]	65,700[71,670]	63,490[69,270]	40,790	34,500	
	ISO	kN	333.4[363.7]	305.0[332.7]	294.2[321.0]	186.1	156.9	
		kgf	34,000[37,090]	31,100[33,930]	30,000[32,730]	18,980	16,000	
		lbf	74,960[81,770]	68,560[74,800]	66,140[72,160]	41,840	35,270	

Note : Boom weight includes arm cylinder, piping, and pin
Arm weight includes bucket cylinder, linkage, and pin

Dimensions & Working Range

850LC-9 DIMENSIONS

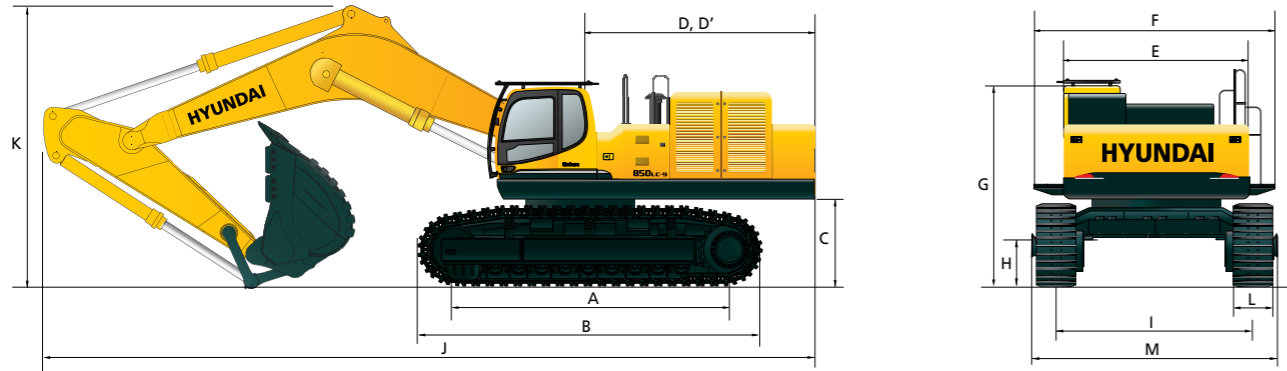

mm (ft-in)

A Tumbler distance	5,030 (16' 6")	Boom length	7,200 (23' 7")	8,050 (26' 5")	8,200 (26' 11")	10,500 (34' 5")	11,300 (37' 1")
B Overall length of crawler	6,335 (20' 9")	Arm length	2,950 (9' 8")	3,400 (11' 2")	3,600 (11' 10")	6,500 (21' 4")	8,000 (26' 3")
C Ground clearance of counterweight	1,580 (5' 2")	J Overall length	13,100 (43' 0")	13,950 (45' 9")	14,110 (46' 4")	16,120 (52' 11")	16,500 (54' 2")
D Tail swing radius	4,315 (14' 2")	K Overall height of boom	5,040 (16' 6")	5,360 (17' 7")	5,390 (17' 8")	5,500 (18' 1")	7,020 (23' 0")
D' Rear-end length	4,200 (13' 9")	L Track shoe width	700 (28")		800 (32")	900 (36")	
E Overall width of upperstructure	3,420 (11' 3")	M Overall width	Extended	4,495 (14' 9")	4,495 (14' 9")	4,595 (15' 1")	
F Overall width with catwalk	4,230 (13' 11")		Retracted	3,775 (12' 5")	3,775 (12' 5")	3,875 (12' 9")	
G Overall height of cab	3,710 (12' 2")						
H Min. ground clearance	880 (2' 11")						
I Track gauge (Extended/Retracted)	3,500 (11' 6") / 2,780 (9' 1")						

850LC-9 WORKING RANGE

mm (ft-in)

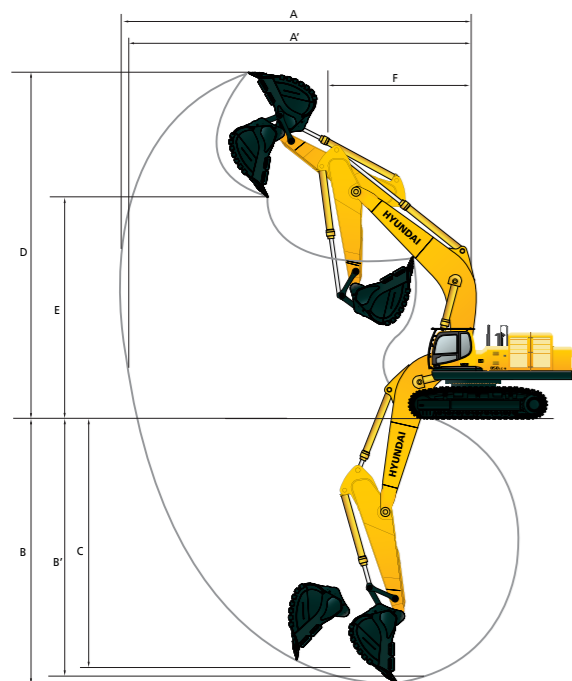

Boom length	7,200 (23' 7")	8,050 (26' 5")	8,200 (26' 11")	10,500 (34' 5")	11,300 (37' 1")
Arm length	2,950 (9' 8")	3,400 (11' 2")	3,600 (11' 10")	6,500 (21' 4")	8,000 (26' 3")
A Max. digging reach	12,250 (40' 2")	13,420 (44' 0")	13,670 (44' 10")	18,470 (60' 7")	20,540 (67' 5")
A' Max. digging reach on ground	11,970 (39' 3")	13,160 (43' 2")	13,420 (44' 0")	18,280 (59' 12")	20,360 (66' 10")
B Max. digging depth	7,240 (23' 9")	8,450 (27' 9")	8,750 (28' 8")	13,040 (42' 9")	14,940 (49' 0")
B' Max. digging depth (8' level)	7,080 (23' 3")	8,320 (27' 4")	8,630 (28' 4")	12,940 (42' 5")	14,840 (48' 8")
C Max. vertical wall digging depth	5,670 (18' 7")	6,190 (20' 4")	6,170 (20' 3")	12,190 (39' 12")	13,990 (45' 11")
D Max. digging height	11,750 (38' 7")	11,820 (38' 9")	11,780 (38' 8")	15,050 (49' 5")	16,190 (53' 1")
E Max. dumping height	7,500 (24' 7")	7,740 (25' 5")	7,770 (25' 6")	11,680 (38' 4")	13,090 (42' 11")
F Min. swing radius	5,120 (16' 10")	6,000 (19' 8")	6,080 (19' 11")	7,620 (25' 0")	8,070 (26' 6")

Dimensions & Working Range

850LC-9 FS DIMENSIONS

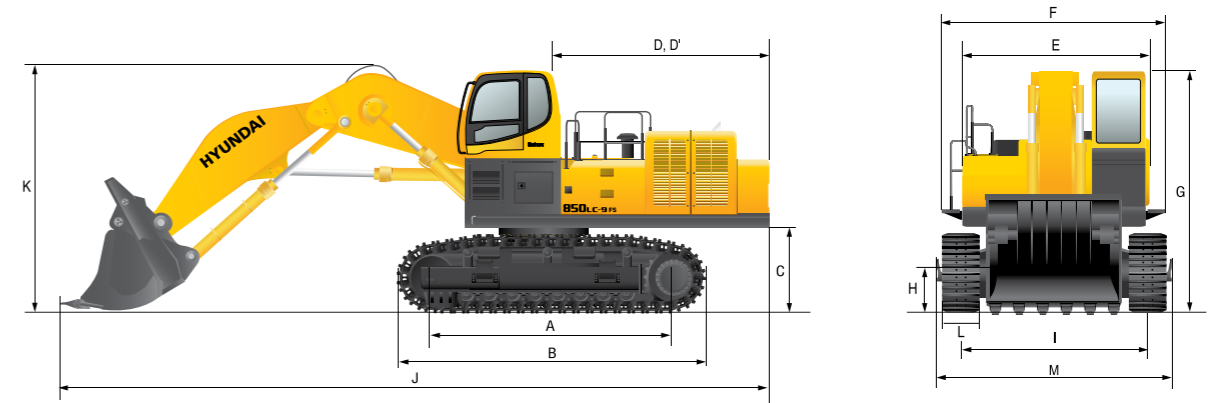

mm (ft-in)

A Tumbler distance	5,030 (16' 6")	Boom length	4,600 (15' 1")		
B Overall length of crawler	6,335 (20' 9")	Arm length	3,500 (11' 6")		
C Ground clearance of counterweight	1,580 (5' 2")	J Overall length	13,700 (44' 11")		
D Tail swing radius	4,315 (14' 2")	K Overall height of boom	5,360 (17' 7")		
D' Rear-end length	4,200 (13' 9")	L Track shoe width	700 (28")	800 (32")	900 (35")
E Overall width of upperstructure	3,420 (11' 3")	M Overall width	Extended	4,495 (14' 9")	4,595 (15' 1")
F Overall width with catwalk	4,230 (13' 11")		Retracted	3,775 (12' 5")	3,875 (12' 9")
G Overall height of cab	3,710 (12' 2")				
H Min. ground clearance	880 (2' 11")				
I Track gauge (Extended/Retracted)	3,500 (11' 6") / 2,780 (9' 1")				

850LC-9 FS WORKING RANGE

mm (ft-in)

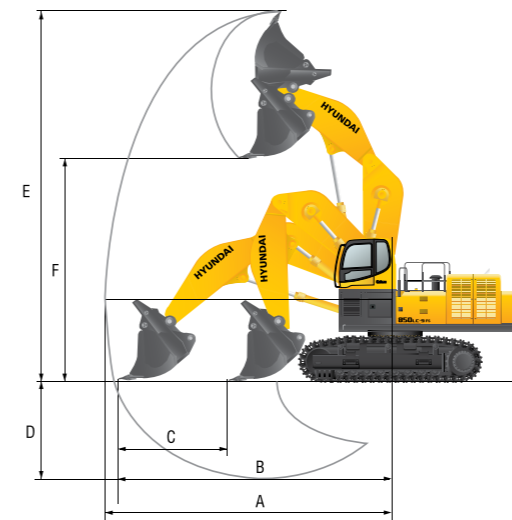

Boom length	4,600 (15' 1")	
Arm length	3,500 (11' 6")	
A Max. digging reach	10,190 (33' 5")	
B Max. reach on ground level	9,730 (31' 11")	
C Max. level crowd distance	3,730 (12' 3")	
D Max. digging depth	2,710 (8' 11")	
E Max. digging height	11,510 (37' 9")	
F Max. dumping height	7,270 (23' 10")	

Transportation Plan

850LC-9

Total (Shipping position(Retracted))

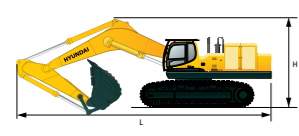

Shoe	Dimension mm(ft · in)			Weight kg(lb)
	L	H	W	
700 (24")	13,100 (43' 0")	5,040 (16' 6")	4,290 (14' 1")	84,000 (185,190)
800 (32")	13,100 (43' 0")	5,040 (16' 6")	4,290 (14' 1")	84,810 (186,970)
900 (35")	13,100 (42' 12")	5,040 (16' 6")	4,290 (14' 1")	85,620 (188,760)

Upperstructure + Undercarriage + Hand Rail + Step Plate

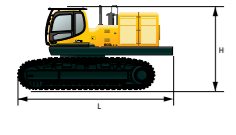

Shoe	Dimension mm(ft · in)			Weight kg(lb)
	L	H	W	
700 (24")	7,150 (23' 5")	3,870 (12' 8")	3,675 (12' 1")	52,025 (114,700)
800 (32")	7,150 (23' 5")	3,870 (12' 8")	3,775 (12' 5")	52,835 (116,480)
900 (35")	7,150 (23' 5")	3,870 (12' 8")	3,885 (12' 9")	53,645 (118,270)

Track Frame



Shoe	Dimension mm(ft · in)			Weight kg(lb)
	L	H	W	
700 (24")	6,335 (20' 9")	1,390 (4' 7")	860 (2' 10")	13,500 (29,760)
800 (32")	6,335 (20' 9")	1,390 (4' 7")	910 (2' 12")	13,905 (30,660)
900 (35")	6,335 (20' 9")	1,390 (4' 7")	960 (3' 2")	14,310 (31,550)

Bucket

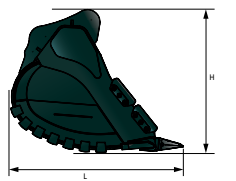

m ³ (yd ³)	Dimension mm(ft · in)			Weight kg(lb)
	L	H	W	
1.65 (2.16)	1,940 (6' 36")	1,680 (5' 6")	1,290 (4' 3")	1,520 (3,350)
2.56 (3.35)	1,940 (6' 4")	1,680 (5' 6")	1,790 (5' 10")	1,870 (4,120)
⊕ 3.40 (4.45)	2,550 (8' 4")	2,130 (6' 12")	1,740 (5' 9")	4,470 (9,850)
⊕ 4.04 (5.28)	2,550 (8' 4")	2,130 (6' 12")	1,970 (6' 6")	4,890 (10,780)
⊕ 4.50 (5.89)	2,550 (8' 4")	2,130 (6' 12")	2,125 (6' 12")	5,120 (11,290)
⊕ 4.85 (6.34)	2,550 (8' 4")	2,130 (6' 12")	2,255 (7' 5")	5,073 (11,180)
⊕ 3.40 (4.45)	2,510 (8' 3")	1,980 (6' 6")	1,700 (5' 7")	3,795 (8,370)
⊕ 3.40 (4.45)	2,550 (8' 4")	2,130 (6' 12")	1,740 (5' 9")	4,610 (10,160)
⊕ 4.04 (5.28)	2,550 (8' 4")	2,130 (6' 12")	1,970 (6' 6")	5,020 (11,070)
⊕ 4.25 (5.56)	2,550 (8' 4")	2,130 (6' 12")	2,040 (6' 8")	5,150 (11,350)
⊕ 4.50 (5.89)	2,550 (8' 4")	2,130 (6' 12")	2,125 (6' 12")	5,250 (11,570)

Catwalk & Step Plate (4EA / Unit)

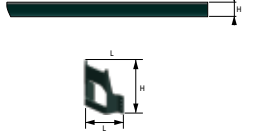

Catwalk	Dimension mm(ft · in)			Weight kg(lb)
	L	H	W	
Step Plate	460 (1' 6")	420 (1' 5")	190 (0' 7")	23 (50)

Upperstructure+ Hand Rail + Undercarriage(700mm shoe) + Boom + Cylinder

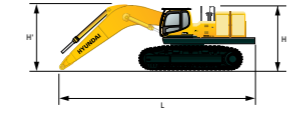

Boom	Dimension mm(ft · in)				Weight kg(lb)
	L	H	H	W	
7.2m (23' 7")	10,720 (35' 2")	4,450 (14' 7")	3,870 (12' 8")	3,675 (12' 1")	61,500 (135,580)
8.05m (26' 5")	11,800 (38' 9")	4,850 (15' 11")	3,870 (12' 8")	3,675 (12' 1")	62,310 (137,370)
8.2m (26' 11")	11,800 (38' 9")	4,650 (15' 3")	3,870 (12' 8")	3,675 (12' 1")	63,120 (139,160)

Upperstructure



L	Dimension mm(ft · in)		Weight kg(lb)
	H	W	
5,945 (19' 6")	2,940 (9' 8")	3,420 (11' 3")	24,650 (54,340)

Boom & Arm Cylinder

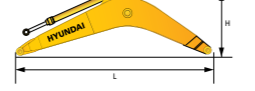

Boom	Dimension mm(ft · in)			Weight kg(lb)
	L	H	W	
7.2m (23' 7")	7,530 (24' 8")	2,735 (8' 12")	1,340 (4' 5")	7,765 (17,120)
8.05m (26' 5")	8,375 (27' 6")	2,980 (9' 9")	1,340 (4' 5")	8,345 (18,400)
8.2m (26' 11")	8,550 (28' 1")	2,985 (9' 10")	1,340 (4' 5")	8,800 (19,400)
10.5m (34' 5")	10,880 (35' 8")	2,470 (8' 1")	1,170 (3' 10")	8,480 (18,700)
11.3m (37' 1")	11,680 (38' 4")	2,370 (7' 9")	1,170 (3' 10")	8,150 (17,970)

Arm & Bucket Cylinder

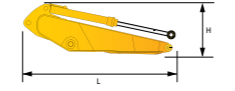

L	Dimension mm(ft · in)		Weight kg(lb)	
	H	W		
2.95m (9' 8")	4,540 (14' 11")	1,435 (4' 8")	800 (2' 7")	4,520 (9,960)
3.4m (11' 2")	4,990 (16' 4")	1,360 (4' 6")	800 (2' 7")	4,635 (10,220)
3.6m (11' 10")	5,235 (17' 2")	1,435 (4' 8")	800 (2' 7")	4,850 (10,690)
6.5m (21' 4")	8,050 (26' 5")	1,320 (4' 4")	530 (1' 9")	5,200 (11,460)
8.0m (26' 3")	9,550 (31' 4")	1,250 (4' 1")	530 (1' 9")	5,300 (11,680)

Boom Cylinder (2EA Weight : 750 x 2 = 1,500kg)



L	Dimension mm(ft · in)		Weight kg(lb)
	H	W	
3,160 (10' 4")	518 (1' 8")	335 (1' 1")	750(1EA) (1,650)

Counter Weight



L	Dimension mm(ft · in)		Weight kg(lb)
	H	W	
3,420 (11' 3")	1,440 (4' 9")	790 (2' 7")	12,600 (27,780)
L/Reach (11' 3")	1,440 (4' 9")	790 (2' 7")	15,500 (34,170)

Hand Rail

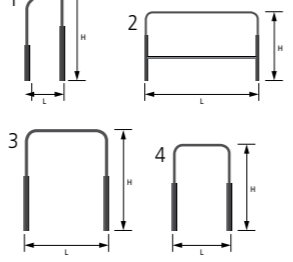

L	Dimension mm(ft · in)		Weight kg(lb)
	H	W	
505 (1' 8")	1,317 (4' 4")	220 (0' 9")	11.1 (20)
1,533 (5' 0")	917 (3' 0")	510 (1' 8")	22.5 (50)
830 (2' 9")	873 (2' 10")	355 (1' 2")	10.4 (20)
830 (2' 9")	917 (3' 0")	145 (0' 6")	10.4 (20)

Transportation Plan

850LC-9 FS

Total (Shipping position(Retracted))

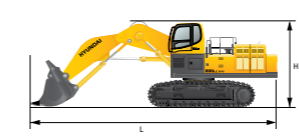

Shoe	Dimension mm(ft · in)			Weight kg(lb)
	L	H	W	
700 (24")	13,700 (44' 11")	5,100 (16' 9")	4,290 (14' 1")	87,800 (193,570)
800 (32")	13,700 (44' 11")	5,100 (16' 9")	4,290 (14' 1")	88,560 (195,240)
900 (35")	13,700 (44' 11")	5,100 (16' 9")	4,290 (14' 1")	89,320 (196,920)

Upperstructure +Hand Rail



L	Dimension mm(ft · in)		Weight kg(lb)
	H	W	
5,800 (19' 0")	3,290 (10' 8")	3,620 (11' 11")	25,100 (55,340)

Attachment Total



L	Dimension mm(ft · in)		Weight kg(lb)
	H	W	
9,050 (29' 8")	4,400 (14' 5")	2,520 (8' 3")	20,345 (44,850)

Boom & Piping

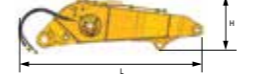

Boom	Dimension mm(ft · in)			Weight kg(lb)
	L	H	W	
4.60m (15' 1")	4,980 (16' 4")	1,700 (5' 7")	1,400 (4' 7")	6,655 (14,670)

Arm & Piping



Arm	Dimension mm(ft · in)			Weight kg(lb)
	L	H	W	
3.50m (11' 6")	3,930 (12' 11")	1,300 (4' 3")	1,200 (3' 11")	4,020 (8,860)

Bucket

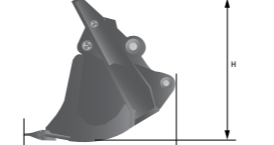

m ³ (yd ³)	Dimension mm(ft · in)			Weight kg(lb)
	L	H	W	
4.50 (5.89)	2,610 (8' 7")	2,270 (7' 5")	2,520 (8' 3")	7,660 (16,890)
4.80 (6.28)	2,620 (8' 7")	2,400 (7' 10")	2,520 (8' 3")	8,030 (17,700)

Catwalk & Step Plate (4EA / Unit)

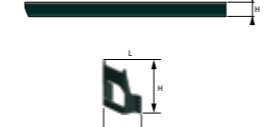

Catwalk	Dimension mm(ft · in)			Weight kg(lb)
	L	H	W	
Step Plate	460 (1' 6")	420 (1' 5")	240 (0' 9")	23 (50)

Upperstructure + Undercarriage + Hand Rail + Step Plate

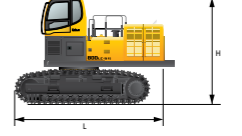

Boom	Dimension mm(ft · in)				Weight kg(lb)
	L	H	W	W	
700 (24")	6,950 (22' 10")	4,670 (15' 3")	3,675 (12' 1")	3,675 (12' 1")	52,475 (115,690)
800 (32")	6,950 (22' 10")	4,670 (15' 3")	3,775 (12' 5")	3,775 (12' 5")	53,235 (117,360)
900 (35")	6,950 (22' 10")	4,670 (15' 3")	3,885 (12' 9")	3,885 (12' 9")	53,995 (119,040)

Counter Weight



L	Dimension mm(ft · in)		Weight kg(lb)
	H	W	
3,420 (11' 3")	1,440 (4' 9")	790 (2' 7")	12,600 (27,780)

Boom Cylinder (2EA Weight : 645 x 2 = 1,290kg)

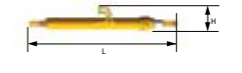

L	Dimension mm(ft · in)		Weight kg(lb)
	H	W	
3,000 (9' 10")	520 (1' 8")	370 (1' 3")	645 (1,420)

Arm Cylinder

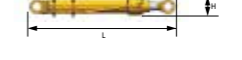

L	Dimension mm(ft · in)		Weight kg(lb)
	H	W	
2,680 (8' 10")	350 (1' 2")	370 (1' 3")	730 (1,610)

Bucket Cylinder (2EA Weight : 640 x 2 = 1,280kg)



L	Dimension mm(ft · in)		Weight kg(lb)
	H	W	
3,530 (11' 7")	385 (1' 3")	330 (1' 1")	640 (1,410)

Track Frame (1EA)

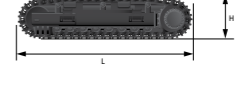

Shoe	Dimension mm(ft · in)			Weight kg(lb)
	L	H	W	
700 (24")	6,335 (20' 9")	1,390 (4' 7")	860 (2' 10")	13,500 (29,760)
800 (32")	6,335 (20' 9")	1,390 (4' 7")	910 (2' 12")	13,905 (30,660)
900 (35")	6,335 (20' 9")	1,390 (4' 7")	960 (3' 2")	14,310 (31,550)

Hand Rail

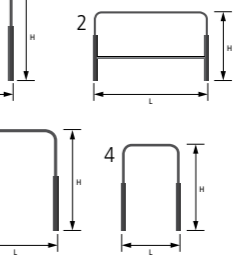

L	Dimension mm(ft · in)		Weight kg(lb)
	H	W	
505 (1' 8")	1,317 (4' 4")	220 (0' 9")	11.1 (20)
1,533 (5' 0")	917 (3' 0")	510 (1' 8")	22.5 (50)
830 (2' 9")	873 (2' 10")	355 (1' 2")	10.4 (20)
830 (2' 9")	917 (3' 0")	145 (0' 6")	10.4 (20)

