

MOVING YOU FURTHER

Robex 180w-95

With Tier 2 Engine installed



*Photo may include optional equipment.

PLEASE CONTACT

 **HYUNDAI CONSTRUCTION EQUIPMENT**

Pride at Work

Hyundai Heavy Industries strives to build state-of-the-art earthmoving equipment to give every operator maximum performance, more precision, versatile machine preferences, and proven quality. Take pride in your work with Hyundai!

Robex 180w-95

Machine Walk-Around

Engine Technology

Proven and reliable, fuel efficient Mitsubishi Tier II S6S-DT engine
Low noise / Auto engine warm up feature / Anti-restart feature

Hydraulic System Improvements

New patented hydraulic control system for improved controllability / Improved control valve design for added efficiency and smoother operation / New auto boom and swing priority system for optimum speed / New auto power boost feature for additional power when needed / Improved arm-in flow regeneration system for added speed and efficiency

Pump Compartment

Industry-leading, powerful, reliable Kawasaki designed, variable volume in-line axial piston pumps
New compact solenoid block equipped with 3 solenoid valves, 1 EPPR valve, 1 check valve accumulator and pilot filter-controls safety lock, power boost, arm-in regeneration control, boom priority (swing logic valve control)
Remotely mounted fuel, engine oil and case drain filters for maximum convenience while servicing

Carrier

Heavy duty carrier frame with two speed powershift transmission
Heavy duty drive line and axles / Front axle oscillation +/- 7 degrees with ram lock
Wet disc brake (front & rear) / Automatic parking brake - spring applied, hydraulically released

Improved Steering Column

Slim-profile steering column capable of telescoping 60 mm and tilting 30 degrees

Enhanced Operator Cab

Improved visibility

Enlarged cab with improved visibility
Larger right-side glass, now one piece, for better right visibility
Safety glass windows on all sides - less expensive than (polycarbonate) and won't scratch or fade
Reduced front window seam for improved operator view

Improved Cab Construction

New steel tube construction for added operator safety, protection and durability
New window open/close mechanism designed with cable and spring lift assist and single latch release

Improved Suspension Seat / Console Assembly

Ergonomic joysticks with auxiliary control buttons for attachment use, now with new sleek styling
Adjustable arm rests - turn dial to raise or lower for optimum comfort

Advanced 7" Color Cluster

New color LCD display with easy-to-read digital gauges for hydraulic oil temperature, water temperature, and fuel. Simplified design makes adjustment and diagnostics easier. Also, new enhanced features such as rear-view camera are integrated into monitor
3 power modes : (P) Power, (S) Standard, (E) Economy, 2 work modes : Dig & Attachment, (U) User mode for operator preference
Enhanced self-diagnostic features with GPS/satellite technology
One pump flow or two pump flow for optional attachment now selectable through the cluster
New anti-theft system with password capability
Boom speed and arm regeneration are selectable through the monitor
Auto power boost is now available - selectable (on/off) through the monitor
Powerful air conditioning and heat with auto climate control, 20% more heat and air output than 7 series!
Hi-MATE (Remote Management System) works through GPS/Satellite technology to ultimately provide better customer service and support

*Photo may include optional equipment.

Preference

Operating a 9S Series is unique to every operator. Operators can fully customize their work environment and operating preferences to fit their individual needs.



*Photo may include optional equipment.



Wide Cabin with Excellent Visibility

The newly designed cabin was conceived for more space, a wider field of view and operator comfort. Special attention was given to a clear, open and convenient interior with plenty of visibility on the machine surroundings and the job at hand. This well balanced combination of precision aspects put the operator in the perfect position to work safely and securely.

Operator Comfort

In a 9S series cabin you can easily adjust the seat, console and armrest settings to best suit your personal operating preferences. Seat and console position can be set together and independent from each other. Improved steering wheel telescope and tilt functions provide operators improved access. A fully automatic, high capacity airconditioning system maintains a constant preferred temperature.



Reduced Stress

Work is stressful enough. Your work environment should be stress free. Hyundai's 9S Series provides improved cab amenities, additional space and a comfortable seat to minimize stress to the operator. A powerful climate control system provides the operator with optimum air temperature. An advanced audio system with USB player, AM/FM stereo is perfect for listening to music favorites.



Operator - Friendly Cluster

The advanced new cluster with 7 inch wide color LCD screen and toggle switch allows the operator to select his personal machine preferences. Power and work mode selection, self diagnostics, optional rear-view camera, maintenance check lists, start-up machine security were integrated into the cluster to make the machine more versatile and the operator more productive.



Precision

Innovative hydraulic system technologies make the 9S Series excavator fast, smooth and easy to control.



Computer Aided Power

The engine horsepower and hydraulic horsepower together in unison through the advanced CAPO(Computer Aided Power Optimization) system, flow for the job at hand. Operator can set their own preferences for boom or swing priority, power mode selection and optional work tools at the touch of a button.

The CAPO system also provides complete self diagnostic features and digital gauges for important information like hydraulic oil temperature, water temperatures and fuel level. This system interfaces with multiple sensors placed throughout the hydraulic system as well as hydraulic flow.

Power Mode

P (Power Max) mode maximizes machine speed and power for mass production. S (Standard) mode provides a reduced, fixed rpm for optimum performance and improved fuel economy. For maximum fuel savings and improved control, E (Economy) mode provides precise flow based on load demand. Three unique power modes provide the operator with custom power, speed and fuel economy.

Work Mode

The work mode allows the operator to select single flow attachments like a hydraulic breaker or bi-directional flow attachments like a crusher. Flow settings unique to each attachment can be programmed from within the cluster.

User Mode

Some jobs require more precise machine settings. Using the versatile U (User) mode, the operator can customize engine speed, pump output, idle speed and other machine settings for the job at hand.

Improved Hydraulic System



To achieve optimum precision, Hyundai redesigned the hydraulic system to provide the operator with super fine touch and improved controllability. Improved pump flow control reduces flow when controls are not being used to minimize fuel consumption.

Improved spool valves in the control valve are engineered to provide more precise flow to each function with less effort.

Improved hydraulic valves, precision-designed variable volume piston pumps, fine-touch pilot controls, and enhanced travel functions make any operator running a 9S Series look like a smooth operator. Newly improved features

include arm-in and boom-down flow regeneration, improved control valve technology and innovative auto boom and swing priority for optimal performance in any application.

Auto Boom-swing Priority

This smart function automatically and continuously looks the ideal hydraulic flow balance for the boom and swing motions of the machine. The advanced CAPO system monitors the hydraulic system and adjusts its settings to maximize performance and productivity.



*Photo may include optional equipment.

Performance

9S Series is designed for maximum performance to keep the operator working productively.



*Photo may include optional equipment.

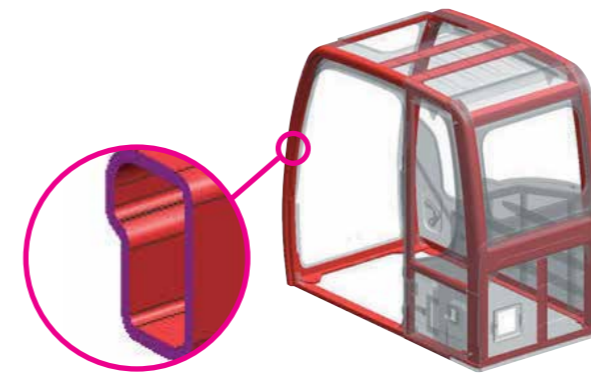

Structural Strength

The 9S series cabin structure has been fitted with stronger but slimmer tubing for more safety and better visibility. Low-stress and high strength steel was integrally welded to form a strong and stable lower frame. Structural durability was evaluated and tested by means of FEM (Finite Elements Method) analysis and long-term durability tests.



Improved Durability

9S series excavators are equipped with stainless spring guards to protect the hoses from external damages. Both dozer and outrigger are equipped with cylinder guards for added protection.

Improved Travel System

A new auto ram lock system is available to improve operating safety. A new optional forward / reverse travel pedal control allows operators to choose to use the travel pedal control while in work mode or lever control when in travel mode.



Auto ram lock system

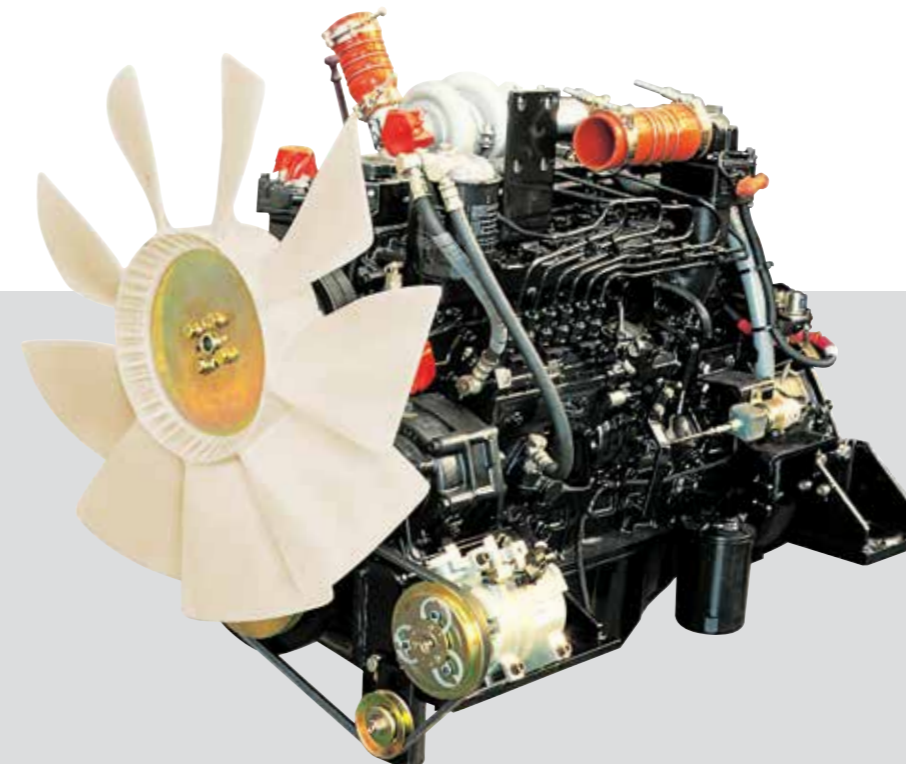

Mitsubishi S6S-DT Engine

Mitsubishi S6S-DT engine is ideal solution for the toughest work environment. The engine is built from a cast iron, skirted block with main bearing support between each cylinder. This combination provides maximum strength, rigidity, and crankshaft support. Special liquid cooling results in uniform temperature distribution.

Profitability

9S Series is designed to maximize profitability through improved efficiencies, enhanced service features and longer life components.



*Photo may include optional equipment.

Fuel Efficiency

9S Series excavators are engineered to be extremely fuel efficient. New innovations like two-stage auto decel system and the new economy mode help to conserve fuel and reduce the impact on the environment.



Hi-MATE (Remote Management System)

Hi-MATE, Hyundai's proprietary remote management system, provides operators and dealer service personnel access to vital service and diagnostic information on the machine from any computer with internet access. Users can pinpoint machine location using digital mapping and set machine work boundaries, reducing the need for multiple service calls. Hi-MATE saves time and money for the owner and dealer by promoting preventative maintenance and reducing machine downtime.



Easy Access

Ground-line access to filters, lube fittings, fuses, machine computer components and wide open compartments makes service more convenient on the 9S Series.



Long-Life Components

9S series excavators were designed with bushings designed for long-life lube intervals (250 hrs) & polymer shims (wear resistant, noise reducing), long-life hydraulic filters (1,000hrs), long-life hydraulic oil (5,000hrs), more efficient cooling systems and integrated preheating systems which extend service intervals, minimize operating costs and reduce machine down time.

Specifications

ENGINE

MODEL		MITSUBISHI S6S-DT	
Type		Water cooled, 4 cycle diesel 6-cylinders in line, direct injection, Turbocharged, charger air cooled low emission	
Rated flywheel horsepower	SAE	J1995 (gross)	126 HP (94kW) at 2,100 rpm
		J1349 (net)	116 HP (87kW) at 2,100 rpm
horsepower	DIN	6271/1 (gross)	128 PS (94kW) at 2,100 rpm
		6271/1 (net)	118 PS (87kW) at 2,100 rpm
Max. torque		42.5 kgf-m(307 lbf-ft) at 1,400 rpm	
Bore X stroke		94 x 120 mm (3.70" x 4.72")	
Piston displacement		4,996 cc (305 in ³)	
Batteries		2 x 12 V x 100 AH	
Starting motor		24V-5.0 kW	
Alternator		24V-50 Amp	

HYDRAULIC SYSTEM

MAIN PUMP	
Type	Two variable displacement piston pumps
Rated flow	2 X 172 L /min (45.4 US gpm/37.8 UK gpm)
Sub-pump for pilot circuit	Gear pump

Cross-sensing and fuel saving pump system

HYDRAULIC MOTORS

Travel	Variable displacement bent-axis axial pistons motor
Swing	Axial piston motor with automatic brake

RELIEF VALVE SETTING

Implement circuits	350 kgf/cm ² (4,970 psi)
Travel	380 kgf/cm ² (5,400 psi)
Power boost (boom, arm, bucket)	380 kgf/cm ² (5,400 psi)
Swing circuit	285 kgf/cm ² (4,050 psi)
Pilot circuit	40 kgf/cm ² (570 psi)
Service valve	Installed

HYDRAULIC CYLINDERS

No. of cylinder bore X stroke	Boom : 2-115 x 1,090 mm (4.5" x 42.9")
	Arm : 1-120 x 1,355 mm (4.7" x 53.3")
	Bucket : 1-110 x 995 mm (4.3" x 39.2")
	Blade : 2-110 x 235 mm (4.3" x 9.3")
	Outrigger : 2-125 x 463 mm (4.9" x 18.2")

DRIVES & BRAKES

4-wheel hydrostatic drive. Constant mesh, helical gear transmission provides 2 forward and reverse travel speeds.

Max. drawbar pull		11,600 kgf (25,570 lbf)
Travel speed	1st	8.4 km/h (5.2 mph)
	2nd	30 km/h (18.6 mph)
Gradeability		35(70 %)

Parking brake : Independent dual brake, front and rear axle full hydraulic power brake.

- Spring released and hydraulic applied wet type multiple disk brake.
- Transmission is locked at neutral position for parking, automatically.

CONTROL

Pilot pressure operated joysticks and pedals with detachable lever provide almost effortless and fatigueless operation.

Pilot control	Two joysticks with one safety lever (LH): Swing and arm, (RH): Boom and bucket (ISO)
Engine throttle	Electric, Dial type

AXLE & WHEEL

Full floating front axle is supported by center pin for oscillation. It can be locked by oscillation lock cylinders. Rear axle is fixed on the lower chassis.

Tires	10.00-20-14PR, Dual(tube type)
(optional)	10.00-20, Dual(solid type)

SWING SYSTEM

Swing motor	Fixed displacement axial pistons motor
Swing reduction	Planetary gear reduction
Swing bearing lubrication	Grease-bathed
Swing brake(option)	Multi wet disc
Swing speed	11 rpm

STEERING SYSTEM

Hydraulically actuated, orbitrol type steering system actuates on front wheels through the steering cylinders.

Min. turning radius	6,300 mm(20' 8")
---------------------	------------------

COOLANT & LUBRICANT CAPACITY

	liter	US gal	UK gal
Re-filling			
Fuel tank	270.0	71.3	59.4
Engine coolant	22.0	5.8	4.8
Engine oil	16.5	4.4	3.6
Swing device - gear oil	5.0	1.3	1.1
Axle	Front	15.5	4.1
	Rear	17.5	4.6
Hydraulic system (including tank)	210.0	55.5	46.2
Hydraulic tank	124.0	32.8	27.3

UNDERCARRIAGE

Reinforced box-section frame is all-welded, low-stress. Dozer blade and outriggers are available. A pin-on design.

Dozer blade	A very useful addition for leveling and back filling or clean-up work.
Outrigger	Indicated for max. operation stability when digging and lifting. Can be mounted on the front or the rear.

OPERATING WEIGHT (APPROXIMATE)

Operating weight, including 5,100mm (16' 9") Mono boom, 2,600mm (8' 6") arm, SAE heaped 0.89m³ (1.16yd³) backhoe bucket, lubricant, coolant, full fuel tank, hydraulic tank and the standard equipment.

MAJOR COMPONENT WEIGHT	
Upperstructure	4,590 kg (10,120 lb)
Mono boom(with arm cylinder)	1,240 kg (2,730 lb)

OPERATING WEIGHT	
Undercarriage	Mono boom
Rear dozer blade	17,300 kg (38,140 lb)
Rear outrigger	17,450 kg (38,470 lb)
Front outrigger and rear blade	18,420 kg (40,610 lb)
Front blade and rear outrigger	18,360 kg (40,480 lb)
Four outrigger	18,600 kg (41,010 lb)

AIR CONDITIONING SYSTEM

The air condition system for the machine contains the fluorinated greenhouse gas with global warming potential of R134a. (Global Warming Potential : 1430)

The system hold 0.75kg refrigerant consisting of a CO₂ equivalent 1.07kg metric tonne. For more information, Please refer to the manual.

BUCKETS

All buckets are welded with high-strength steel.

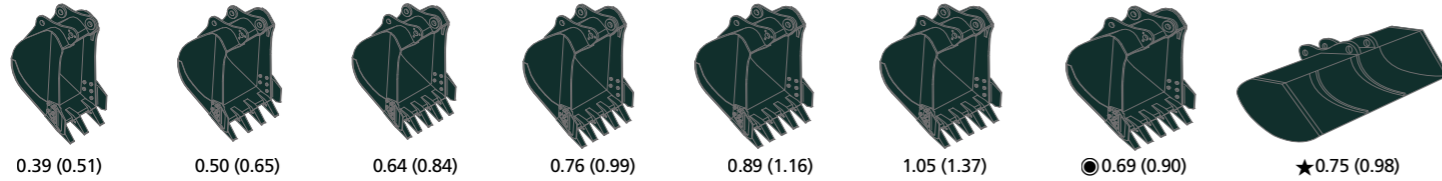

SAE heaped m³ (yd³)

Capacity m ³ (yd ³)		Width mm (in)		Weight kg (lb)	Recommendation mm (ft-in)		
SAE heaped	CECE heaped	Without sidecutters	With sidecutters		5,100 (16' 9") Mono Boom		
					2,200 (7' 3") Arm	2,600 (8' 6") Arm	3,100 (10' 2") Arm
0.39 (0.51)	0.34(0.44)	620(24.4)	740(29.1)	410(900)	●	●	●
0.50 (0.65)	0.44(0.58)	760(29.9)	880(34.6)	470(1040)	●	●	●
0.64 (0.84)	0.55(0.72)	920(36.2)	1,040(40.9)	510(1120)	●	●	■
0.76 (0.99)	0.65(0.85)	1,060(41.7)	1,180(46.5)	570(1260)	●	■	▲
0.89 (1.16)	0.77(1.01)	1,220(48.0)	1,340(52.8)	610(1340)	■	▲	-
1.05 (1.37)	0.90(1.18)	1,400(55.1)	1,520(59.8)	680(1500)	▲	-	-
0.69 (0.90)	0.62(0.81)	990(39.0)	-	700(1540)	●	■	▲
① 0.75 (0.98)	0.65(0.85)	1,800(70.9)	-	540(1190)	■	■	▲

Heavy duty bucket

① Ditching bucket

● : Applicable for materials with density of 2,000 kg /m³ (3,370 lb/ yd³) or less

■ : Applicable for materials with density of 1,600 kg /m³ (2,700 lb/ yd³) or less

▲ : Applicable for materials with density of 1,100 kg /m³ (1,850 lb/ yd³) or less

ATTACHMENT

Boom and arms are welded with a low-stress, full-box section design. 5.1m (16' 9") boom, and 2.2m (7' 3"), 2.6m (8' 6"), 3.1m (10' 2") arms.

DIGGING FORCE

Boom	Length	mm (ft-in)	5,100 (16' 9")			Remarks
	Weight	kg (lb)	1,240 (2,730)			
Arm	Length	mm (ft-in)	2,200 (7' 3")	2,600 (8' 6")	3,100 (10' 2")	Remarks
	Weight	kg (lb)	750 (1,560)	810 (1,790)	890 (1,960)	
Bucket digging force	SAE	kN	107.9 [117.2]	107.9 [117.2]	107.9 [117.2]	[]: Power Boost
		kgf	11,000 [11,940]	11,000 [11,940]	11,000 [11,940]	
		lbf	24,250 [26,330]	24,250 [26,330]	24,250 [26,330]	
	ISO	kN	123.6 [134.2]	123.6 [134.2]	123.6 [134.2]	
		kgf	12,600 [13,680]	12,600 [13,680]	12,600 [13,680]	
		lbf	27,780 [30,160]	27,780 [30,160]	27,780 [30,160]	
Arm crowd force	SAE	kN	87.2 [94.7]	77.3 [83.9]	69.0 [74.9]	
		kgf	8,890 [9,650]	7,880 [8,560]	7,030 [7,630]	
		lbf	19,600 [21,280]	17,270 [18,860]	15,500 [16,830]	
	ISO	kN	91.0 [98.8]	80.3 [87.2]	71.4 [77.5]	
		kgf	9,280 [10,080]	8,190 [8,890]	7,280 [7,900]	
		lbf	20,460 [22,210]	18,060 [19,600]	16,050 [17,430]	

Note: Boom weight includes arm cylinder, piping, and pin

Arm weight includes bucket cylinder, linkage, and pin

Dimensions & Working Range

R180W-9S DIMENSIONS

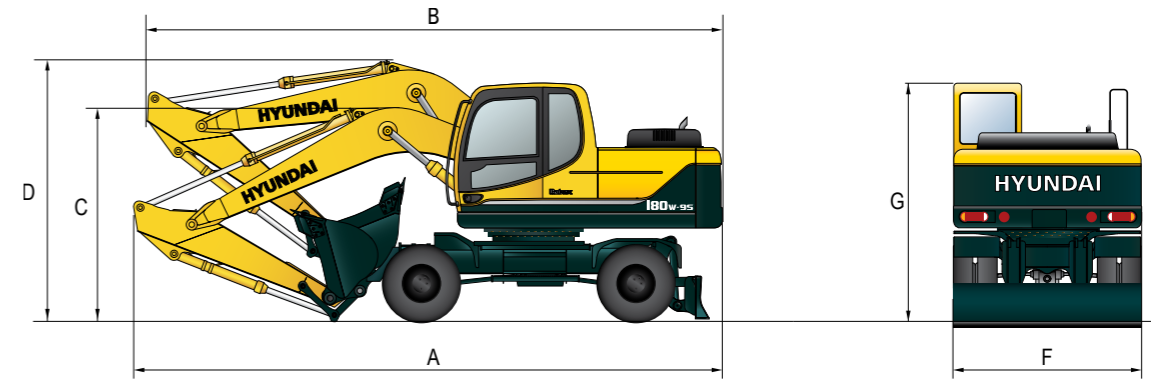

Unit : mm (ft - in)

Mono Boom	5,100(16' 9")		
Arm	2,200 (7' 3")	2,600 (8' 6")	3,100 (10' 2")
A Overall length of shipping position	8,650 (28' 5")	8,730 (28' 8")	8,760 (28' 9")
B Overall length of traveling position	8,590 (28' 2")	8,400 (27' 7")	8,480 (27' 10")
C Height of attachment (shipping position)	3,060 (10' 0")	3,020 (9' 11")	3,150 (10' 4")
D Height of attachment (traveling position)	3,610 (11' 10")	3,940 (12' 11")	3,900 (12' 10")
F Overall width	2,500 (8' 2")	2,500 (8' 2")	2,500 (8' 2")
G Height of cabin	3,190 (10' 6")	3,190 (10' 6")	3,190 (10' 6")

R180W-9S WORKING RANGE

Unit : mm (ft - in)

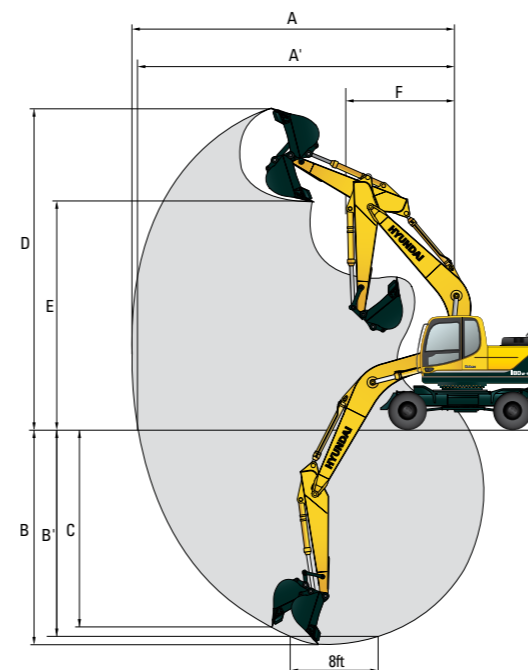

Boom length	5,100 (16' 9")		
Arm length	2,200 (7' 3")	2,600 (8' 6")	3,100 (10' 2")
A Max. digging reach	8,690 (28' 6")	9,020 (29' 7")	9,450 (31' 0")
A' Max. digging reach on ground	8,480 (27' 10")	8,810 (28' 11")	9,250 (30' 4")
B Max. digging depth	5,420 (17' 9")	5,820 (19' 1")	6,320 (20' 9")
B' Max. digging depth (8' level)	5,200 (17' 1")	5,620 (18' 5")	6,130 (20' 1")
C Max. vertical wall digging depth	4,890 (16' 1")	5,140 (16' 10")	5,470 (17' 11")
D Max. digging height	8,990 (29' 6")	9,070 (29' 9")	9,220 (30' 3")
E Max. dumping height	6,350 (20' 10")	6,460 (21' 2")	6,620 (21' 9")
F Min. swing radius	3,180 (10' 5")	3,170 (10' 5")	3,160 (10' 4")

Undercarriage

R180W-9S WITH REAR DOZER AND FRONT REST

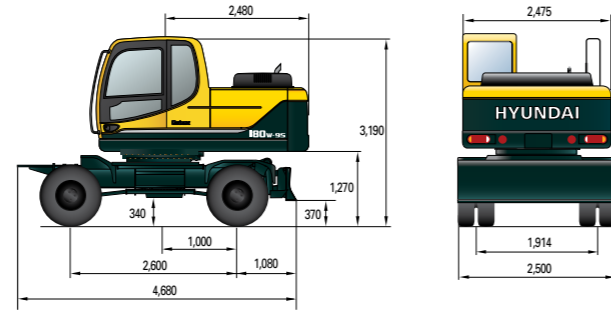

R180W-9S WITH REAR OUTRIGGER AND FRONT REST

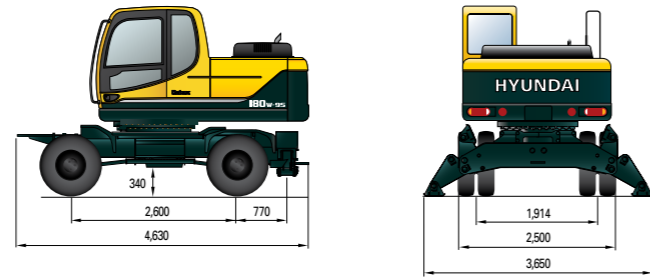

R180W-9S WITH REAR DOZER AND FRONT OUTRIGGER

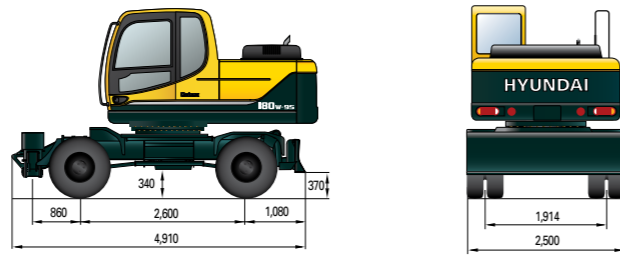

R180W-9S WITH REAR AND FRONT OUTRIGGER

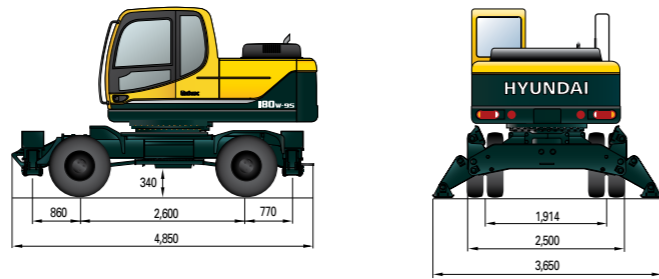

R180W-9S WITH REAR OUTRIGGER AND FRONT DOZER

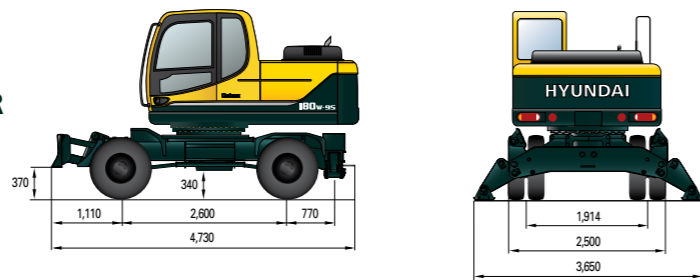

Lifting Capacity

R180W-9S

Rating over-front Rating over-side or 360 degree

Boom : 5.1 m (16' 9") / Arm : 2.2 m (7' 3") / Bucket : 0.76 m³ (0.99 yd³) SAE / Outrigger and dozer blade down(CWT 2750kg, Front Position)

Load point height m (ft)		Load radius								At max. reach		
		1.5 m (5 ft)		3.0 m (10 ft)		4.5 m (15 ft)		6.0 m (20 ft)		Capacity	Reach	
7.5 m (25 ft)	kg									*3710	3220	5.89
	lb									*8180	7100	(19.3)
6.0 m (20 ft)	kg							*3340	3030	*3660	2240	7.15
	lb							*7360	6680	*8070	4940	(23.5)
4.5 m (15 ft)	kg					*4730	*4730	*4170	2970	*3690	1830	7.86
	lb					*10430	*10430	*9190	6550	*8140	4030	(25.8)
3.0 m (10 ft)	kg			*9740	8400	*6000	4480	*4690	2830	3630	1640	8.19
	lb			*21470	18520	*13230	9880	*10340	6240	8000	3620	(26.9)
1.5 m (5 ft)	kg					*7180	4140	*5230	2670	3580	1600	8.19
	lb					*15830	9130	*11530	5890	7890	3530	(26.9)
Ground	kg			*7660	7480	*7720	3950	*5540	2570	3790	1690	7.87
	lb			*16890	16490	*17020	8710	*12210	5670	8360	3730	(25.8)
-1.5 m (-5 ft)	kg	*7650	*7650	*11110	7540	*7510	3910	*5380	2540	*3950	1980	7.18
	lb	*16870	*16870	*24490	16620	*16560	8620	*11860	5600	*8710	4370	(23.6)
-3.0 m (-10 ft)	kg	*12010	*12010	*9250	7720	*6410	3990			*3660	2750	5.95
	lb	*26480	*26480	*20390	17020	*14130	8800			*8070	6060	(19.5)

Boom : 5.1 m (16' 9") / Arm : 2.2 m (7' 3") / Bucket : 0.76 m³ (0.99 yd³) SAE / Outrigger and dozer blade up(CWT 2750kg, Front Position)

Load point height m (ft)		Load radius								At max. reach		
		1.5 m (5 ft)		3.0 m (10 ft)		4.5 m (15 ft)		6.0 m (20 ft)		Capacity	Reach	
7.5 m (25 ft)	kg									*3710	2770	5.89
	lb									*8180	6110	(19.3)
6.0 m (20 ft)	kg							*3340	2590	3590	1900	7.15
	lb							*7360	5710	7910	4190	(23.5)
4.5 m (15 ft)	kg					*4730	4150	*4170	2540	2990	1530	7.86
	lb					*10430	9150	*9190	5600	6590	3370	(25.8)
3.0 m (10 ft)	kg			*9740	6940	*6000	3800	4600	2400	2730	1360	8.19
	lb			*21470	15300	*13230	8380	10140	5290	6020	3000	(26.9)
1.5 m (5 ft)	kg					7060	3470	4430	2250	2690	1320	8.19
	lb					15560	7650	9770	4960	5930	2910	(26.9)
Ground	kg			*7660	6080	6840	3290	4310	2140	2840	1400	7.87
	lb			*16890	13400	15080	7250	9500	4720	6260	3090	(25.8)
-1.5 m (-5 ft)	kg	*7650	*7650	*11110	6140	6790	3250	4280	2110	3310	1650	7.18
	lb	*16870	*16870	*24490	13540	14970	7170	9440	4650	7300	3640	(23.6)
-3.0 m (-10 ft)	kg	*12010	*12010	*9250	6300	*6410	3330			*3660	2310	5.95
	lb	*26480	*26480	*20390	13890	*14130	7340			*8070	5090	(19.5)

Boom : 5.1 m (16' 9") / Arm : 2.6 m (8' 6") / Bucket : 0.76 m³ (0.99 yd³) SAE / Outrigger and dozer blade down(CWT 2750kg, Front Position)

Load point height m (ft)		Load radius										At max. reach			
		1.5 m (5 ft)		3.0 m (10 ft)		4.5 m (15 ft)		6.0 m (20 ft)		7.5 m (25 ft)		Capacity	Reach		
7.5 m (25 ft)	kg												*3360	2830	6.37
	lb												*741n	6240	(20.9)
6.0 m (20 ft)	kg							*3250	3080				*3360	2040	7.53
	lb							*7170	6790				*7410	4500	(24.7)
4.5 m (15 ft)	kg							*3830	2990				*3420	1670	8.20
	lb							*8440	6590				*7540	3680	(26.9)
3.0 m (10 ft)	kg			*8540	*8540	*5530	4530	*4400	2830	*2990	1900		3380	1500	8.52
	lb			*18830	*188.0	*12190	9990	*9700	6240	*6590	4190		7450	3310	(28.0)
1.5 m (5 ft)	kg			*7620	*7620	*6830	4160	*5010	2660	*3710	1820		3330	1460	8.52
	lb			*16800	*16800	*15060	9170	*11050	5860	*8180	4010		7340	3220	(28.0)
Ground	kg			*8230	7420	*7570	3920	*5420	2530	*3250	1760		3500	1530	8.22
	lb			*18140	16360	*16690	8640	*11950	5580	*7170	3880		7720	3370	(27.0)
-1.5 m (-5 ft)	kg	*7190	*7190	*11280	7410	*7570	3840	*5430	2470				*3810	1770	7.56
	lb	*15850	*15850	*24870	16340	*16690	8470	*11970	5450				*8400	3900	(24.8)
-3.0 m (-10 ft)	kg	*10590	*10590	*9950	7550	*6760	3890	*4660	2520				*3700	2360	6.43
	lb	*23350	*23350	*21940	16640	*14900	8580	*10270	5560				*8160	5200	(21.1)
-4.5 m (-15 ft)	kg			*6800	*6800										
	lb			*14990	*14990										

- Lifting capacity is based on SAE J1097, ISO 10567.
- Lifting capacity of the Robex Series does not exceed 75% of the tipping load with the machine on firm, level ground or 87% of full hydraulic capacity.
- The load point is a hook located on the back of the bucket.
- (*) indicates the load limited by hydraulic capacity.

Lifting Capacity

R180W-9S

Rating over-front Rating over-side or 360 degree

Boom : 5.1 m (16' 9") / Arm : 2.6 m (8' 6") / Bucket : 0.76 m³ (0.99 yd³) SAE / Outrigger and dozer blade up(CWT 2750kg, Front Position)

Load point height m (ft)		Load radius										At max. reach							
		1.5 m (5 ft)		3.0 m (10 ft)		4.5 m (15 ft)		6.0 m (20 ft)		7.5 m (25 ft)		Capacity	Reach						
														m (ft)					
7.5 m (25 ft)	kg															*3360	2430	6.37	
	lb															*7410	5360	(20.9)	
6.0 m (20 ft)	kg																3290	1720	7.53
	lb																7250	3790	(24.7)
4.5 m (15 ft)	kg																2770	1400	8.20
	lb																6110	3090	(26.9)
3.0 m (10 ft)	kg																2540	1240	8.52
	lb																5600	2730	(28.0)
1.5 m (5 ft)	kg																2490	1200	8.52
	lb																5490	2650	(28.0)
Ground	kg																2620	1260	8.22
	lb																5780	2780	(27.0)
-1.5 m (-5 ft)	kg																2990	1460	7.56
	lb																6590	3220	(24.8)
-3.0 m (-10 ft)	kg																*3700	1980	6.43
	lb																*8160	4370	(21.1)
-4.5 m (-15 ft)	kg																		
	lb																		

Boom : 5.1 m (16' 9") / Arm : 3.1 m (11' 1") / Bucket : 0.76 m (0.99 yd) SAE / Outrigger and dozer blade down(CWT 2750kg, Front Position)

Load point height m (ft)		Load radius										At max. reach								
		1.5 m (5 ft)		3.0 m (10 ft)		4.5 m (15 ft)		6.0 m (20 ft)		7.5 m (25 ft)		Capacity	Reach							
														m (ft)						
7.5 m (25 ft)	kg																*3000	2420	6.96	
	lb																*6610	*40	(22.8)	
6.0 m (20 ft)	kg																	*3030	1800	8.02
	lb																	*6680	3970	(26.3)
4.5 m (15 ft)	kg																	*3110	1490	8.65
	lb																	*6860	3280	(28.4)
3.0 m (10 ft)	kg																	3090	1340	8.95
	lb																	6810	2950	(29.4)
1.5 m (5 ft)	kg																	3040	1300	8.95
	lb																	6700	2870	(29.4)
Ground	kg																	3170	1350	8.67
	lb																	6990	2980	(28.4)
-1.5 m (-5 ft)	kg																	3570	1540	8.05
	lb																	7870	3400	(26.4)
-3.0 m (-10 ft)	kg																	*3620	1990	7.01
	lb																	*7980	4390	(23.0)
-4.5 m (-15 ft)	kg																	*3220	*3220	5.23
	lb																	*7100	*7100	(17.2)

Boom : 5.1 m (16' 9") / Arm : 3.1 m (11' 1") / Bucket : 0.76 m (0.99 yd) SAE / Outrigger and dozer blade up(CWT 2750kg, Front Position)

Load point height m (ft)		Load radius										At max. reach									
		1.5 m (5 ft)		3.0 m (10 ft)		4.5 m (15 ft)		6.0 m (20 ft)		7.5 m (25 ft)		Capacity	Reach								
														m (ft)							
7.5 m (25 ft)	kg																	*3000	2060	6.96	
	lb																	*6610	4540	(22.8)	
6.0 m (20 ft)	kg																		2940	1510	8.02
	lb																		6480	3330	(26.3)
4.5 m (15 ft)	kg																		2510	1230	8.65
	lb																		5530	2710	(28.4)
3.0 m (10 ft)	kg																		2310	1090	8.95
	lb																		5090	2400	(29.4)
1.5 m (5 ft)	kg																		2260	1050	8.95
	lb																		4980	2310	(29.4)
Ground	kg																		2360	1090	8.67
	lb																		5200	2400	(28.4)
-1.5 m (-5 ft)	kg																		2660	1260	8.05
	lb																		5860	2780	(26.4)
-3.0 m (-10 ft)	kg																		3360	1640	7.01
	lb																		7410	3620	(23.0)
-4.5 m (-15 ft)	kg																		*3220	2800	5.23
	lb																		*7100	6170	(17.2)

- Lifting capacity is based on SAE J1097, ISO 10567.
- Lifting capacity of the Robex Series does not exceed 75% of the tipping load with the machine on firm, level ground or 87% of full hydraulic capacity.
- The load point is a hook located on the back of the bucket.
- (*) indicates the load limited by hydraulic capacity.

STANDARD EQUIPMENT

- ISO Standard cabin
- All-weather steel cab with 360° visibility
- Safety glass windows
- Rise-up type windshield wiper
- Sliding fold-in front window
- Sliding side window(LH)
- Lockable door
- Hot & cool box
- Storage compartment & Ashtray
- Cabin roof-steel cover
- Radio & USB Player
- 12 volt power outlet (24V DC to 12V DC converter)
- Computer aided power optimization (New CAPO) system
- 3-power mode, 2-work mode, user mode
- Auto deceleration & one-touch deceleration system
- Auto warm-up system
- Auto overheat prevention system
- Automatic climate control
- Air conditioner & heater
- Defroster
- Self-diagnostics system
- Starting Aid (air grid heater) for cold weather
- Centralized monitoring
- LCD display
- Engine speed or Trip meter/Accel.
- Clock
- Gauges
- Fuel level gauge
- Engine coolant temperature gauge
- Hyd. oil temperature gauge
- Warnings
- Check Engine
- Communication error
- Low battery
- Air cleaner clogging
- Indicators
- Max power
- Low speed/High speed
- Fuel warmer
- Auto idle
- Door and cab locks, one key
- Two outside rearview mirrors
- Fully adjustable suspension seat with seat belt
- Pilot-operated slidable joystick
- Two front working lights
- Electric horn
- Batteries (2 x 12V x 100 AH)
- Battery master switch
- Removable clean-out dust net for cooler
- Automatic swing brake
- Removable reservoir tank
- Fuel pre-filter with fuel warmer
- Boom holding system
- Arm holding system
- Accumulator for lowering work equipment
- Electric Transducer
- Lower frame under cover (Normal)
- Tires-dual (10.00-20-14PR)
- Travel alarm

OPTIONAL EQUIPMENT

- Fuel filler pump (35 L/min)
- Beacon lamp
- Single-acting piping kit (breaker, etc.)
- Double-acting piping kit (clamshell, etc.)
- Quick coupler
- Booms
- 5.1m, 16' 9"
- Arms
- 2.2m, 7' 3"
- 2.6m, 8' 6"
- 3.1m, 10' 2"
- Climate control
- Air conditioner only
- Heater only
- Cabin FOPS/FOG (ISO/DIS 10262 Level 2)
- FOPS (Falling Object Protective Structure)
- FOG (Falling Object Guard)
- Cabin guard-Front
- Wire net
- Fine net
- Cabin lights
- Cabin front window rain guard
- Sun visor
- Undercarriage
- Rear outrigger
- Rear dozer and front outrigger
- Rear and front outrigger
- Rear outrigger and front dozer
- Rear dozer
- Lower frame under cover (Additional)
- Pre-heating system, coolant
- Tool kit
- Operator suit
- Rearview camera
- Seat
- Mechanical suspension seat with heater
- Tires - dual (10.00 - 20 solid)
- Fenders (Mudguards)
- Hi-mate (Remote Management System)
- Air compressor
- Rear work Lamp

- * Standard and optional equipment may vary. Contact your Hyundai dealer for more information. The machine may vary according to International standards.
- * The photos may include attachments and optional equipment that are not available in your area.
- * Materials and specifications are subject to change without advance notice.
- * All imperial measurements rounded off to the nearest pound or inch.