



ROBEX 110-7

### Standard Equipment

#### ISO standard cabin

- All-weather steel cab with all-around visibility
- Safety glass windows
- Rise-up type windshield wiper
- Sliding fold-in front window
- Sliding side window
- Lockable door
- Hot & cool box
- Accessory box & Ashtray

#### Computer aided power optimization

##### (New CAPO) system

- 3-power mode
- One touch deceleration system
- Auto warm up system
- Auto overheat prevention system

#### Self diagnostic system

##### Starting aid (air grid heater), cold weather

##### Centralized monitoring

- LCD display
- Engine speed
- Clock & Error code
- Gauges
- Fuel level gauge
- Engine coolant temperature gauge
- Hyd. oil temperature gauge
- Warning
- Fuel level
- CPU
- Engine oil pressure
- Engine coolant temperature
- Hyd. oil temperature
- Low battery
- Air cleaner clogging
- Indicator
- Power max
- Preheat & Engine warming-up
- One touch decel

#### Door and cab locks, one key

##### Radio / USB player

- Radio remote switch

#### Two outside rearview mirrors

#### Fully adjustable suspension seat with seat belt

#### Slidable joystick, pilot-operated

#### Console box tilting system(LH.)

#### Three front working lights

#### Electric horn

#### Batteries (2 x 12V x 80AH)

#### Battery master switch

#### Removable clean out screen for oil cooler

#### Automatic swing brake

#### Removable reservoir tank

#### Water separator & fuel pre-filter, fuel line

#### Boom holding system

#### Arm holding system

#### Counterweight (1,450kg, 3,200lb)

#### Mono boom (4.3m, 14' 1")

#### Arm (2.26m, 7' 5")

#### Track shoes (500m, 20")

#### Track rail guard

#### Starting aid (air grid heater), cold weather

#### Fuel warmer

### Optional Equipment

#### Air-conditioner (5,000 kcal/hr, 20,000 BTU/hr)

#### Heater & defroster (7,500 Kcal/hr, 30,000 BTU/hr)

#### Sun visor for cabin inside

#### Fuel filler pump (35l/min, 9.3 US gpm)

#### Beacon lamp

#### Safety lock valve for boom cylinder

#### with overload warning device

#### Safety lock valve for arm cylinder

#### Single acting piping kit (breaker, etc)

#### Double acting piping kit (clamshell, etc)

#### Accumulator, work equipment lowering

#### 12 volt power outlet (24V DC to 12V DC converter)

#### Quick coupler

#### Travel alarm

#### Various optional arms

- Short arm (1.96 m, 6' 5")
- Long arm (2.81 m, 9' 3")

#### Various optional buckets (SAE heaped)

- Standard bucket (0.45 m<sup>3</sup>, 0.59yd<sup>3</sup>)
- Narrow bucket (0.30 m<sup>3</sup>, 0.39yd<sup>3</sup>)
- Narrow bucket (0.40 m<sup>3</sup>, 0.52yd<sup>3</sup>)
- Narrow bucket (0.50 m<sup>3</sup>, 0.65yd<sup>3</sup>)
- Light bucket (0.59 m<sup>3</sup>, 0.77yd<sup>3</sup>)

#### Cabin roof-cover transparent

#### Cabin lights

#### Track shoes

- Triple grousers shoe (600 mm, 24")
- Triple grousers shoe (700 mm, 28")

#### Lower frame under cover

#### Tool kit

#### Operator suit

#### Special cooling

- Air vent type side door

#### Engine emergency control cable

#### Seat

- Adjustable air suspension seat
- Mechanical suspension seat with heater
- Adjustable air suspension seat with heater



Photo may include optional equipment.

We build a better future

Standard and optional equipment may vary. Contact your Hyundai dealer for more information. The machine shown may vary according to International standards. All US measurement rounded off to nearest pounds or inches.

PLEASE CONTACT



*Robex* CRAWLER EXCAVATOR Applied Tier 2 Engine

# 110-7 / 110D-7





## Built for Maximum Power, Performance, Reliability.

A new chapter in construction equipment has now begun.  
Making the dream a reality.



Photo may include optional equipment



## Operator's Comfort is Foremost. Wide Cab Exceeds Industry Standards.



Photo may include optional equipment



### Visibility

- Even more visibility than before, for safer, more efficient operating.



### Excellent ventilation

- Ventilation has been improved by the addition of the larger fresh air intake system, and by providing additional air flow throughout the cab.
- Sliding front and side windows provide improved ventilation.
- A large sunroof offers upward visibility and additional ventilation.



### Comfortable operator environment

- The control levers and seat can be adjusted to provide maximum operator comfort.
- The seat is fully adjustable for optimum operating position, reducing operator fatigue.
- Console boxes slide forward and backward for improved accessibility.
- The proportional pressure controls reduce unnecessary exertion while ensuring precise operation.
- Large windows allow excellent visibility in all directions.



### Visibility

- The Robex 7 series was designed with low operation noise in mind.
- Hyundai engineering helps to keep interior and exterior noise levels to a minimum.
- The cab's noise levels have been additionally reduced by improving the door seals for the cab and engine compartments.
- An insulated diesel engine compartment with sound-damping material also reduces noise.



Wide, Comfortable Operating Space



Steel Cover Sunroof



Dial Type Engine Speed Switch and Key Switch

## Operating Environment

### The best working conditions in a pleasant environment.

- 1 Centralized control panel
- 2 Horn button
- 3 Option button
- 4 Remote Radio control
- 5 Travel lever
- 6 Cluster
- 7 One touch decel button
- 8 Hour meter
- 9 Travel pedal
- 10 Fully adjustable suspension seat
- 11 Safety lever
- 12 Power boost button
- 13 Joystick control lever
- 14 Air Conditioner and Heater controller

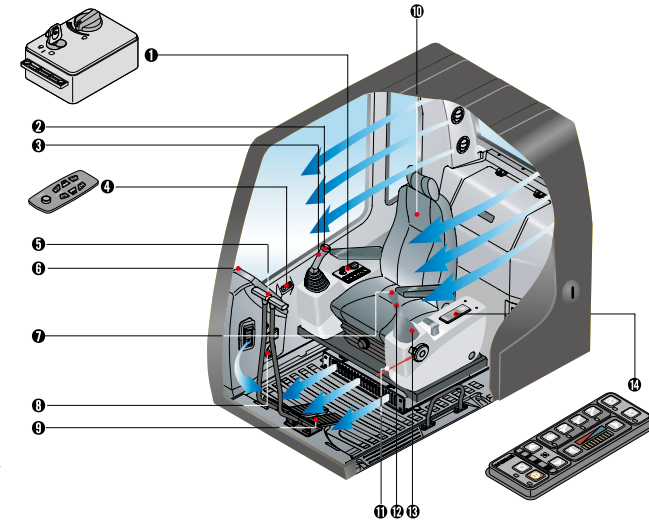

### Rear Emergency Exit Window

Rear Exit Window is designed with easy exit for operator's safety.



### Rise-up Wiper and Cabin Lights

Raise-up wiper has enhanced for the better front view. Cabin Lights enhances safety by brightly lighting the surroundings during night work (optional)



### Wide Cab with Excellent Visibility

The cab is roomy and ergonomically designed with low noise level and good visibility. A full view front window and large rear and side windows provide excellent visibility in all directions.



### Highly Sensitive Joystick and Easy Entrance

New joystick grips for precise control have been equipped with double switches. (Left: Power boost / One touch deceleration, Right: Horn/ Optional)



### Wide, Comfortable Operating Space

All the controls are designed and positioned according to the latest ergonomic research. Reinforced pillars have also been added for greater cab rigidity.



### Radio & USB Player with Remote Control

### Smooth Travel Pedal and Foot Rests



### Improved Intelligent Display

Instrument Panel is installed in front of RH console box. It is easy to check all critical systems with easy-to-read indicators



### Easy-to-Reach Control Panels

Switches and other essential controls are located near the operator. This helps keep operator movement to a minimum, enhancing control with less operator fatigue.



### Storage box and Cup Holder

An additional storage box and cup holder are located behind operator's seat, and it keeps food and beverages cool or hot.



## Advanced hydraulic system

### Advanced capo system

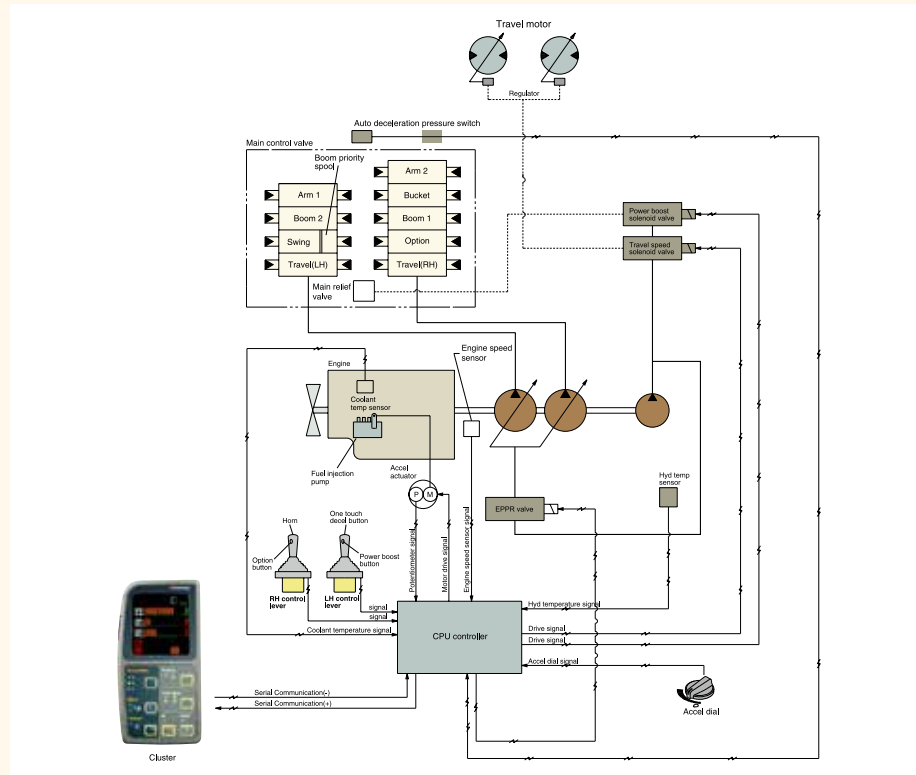

### New mode control system



### Advanced CAPO System

The Advanced CAPO (Computer Aided Power Optimization) system maintains engine and mutual pump power at optimum levels. Mode selections are designed for various work loads and maintaining high performance while reducing fuel consumption. Features such as power boost are included in the system. The system monitors engine speed, coolant temperature, and hydraulic oil temperature. Contained within the system are self diagnostic capabilities, which are displayed by error codes on the cluster.

### Self Diagnosis System

The CPU controller diagnoses problems in the CAPO system caused by electric and hydraulic malfunctions and displays them on the LCD monitor of the cluster by error codes. This controller has the capacity to identify 26 distinct types of errors. As the information from this device, such as engine rpm, main pump delivery pressure, battery voltage, hyd. temperature, and the state of all types of electric switches, provides the operator with a much more exact state of machine operating condition. This makes the machine easier to troubleshoot when anything does go wrong.

### Arm Flow Regeneration System

Arm flow regeneration valve provides smooth arm-in operation without cavitations.

### Boom & Arm Holding System

The Holding valves in the main control valve prevents the boom & arm from dropping over an extended period in neutral position.

### One Touch Deceleration



When the one touch deceleration button on top of LH joystick is pushed once, the engine rpm will be immediately down to low idle rpm. Engine speed will be recovered to its preselected rpm in case the button is pushed once more.

### Automatic Engine Overheat Prevention

If the engine coolant temperature gets too high, the CPU controller lowers the engine speed and cools the engine.

### Anti Restart System

The new system protects the starter from restarting during engine operation, even if the operator accidentally turns the start key again.

### Power boost control System

When the power boost system is activated, digging power increases about 10%. It is especially useful when extra power is temporarily needed, for instance, when digging hard earth and rock, or if the bucket teeth are stopped by a stubborn tree root.

### Automatic Warming-up System

After the engine is started, if the engine coolant temperature is low, the CPU controller increases the engine speed and automatically to warm up the engine more effectively.

### Pump Flow Control System

In neutral position: Pump flow is reduced to a minimum to eliminate power loss. In operation: Maximum pump flow is delivered to the actuator to increase the speed. With movement of the control lever, pump flow is automatically adjusted and the actuator speed can be proportionally controlled.

### Hydraulic Damper in Travel Pedal

Improved travel controllability & feeling by shock reducing when starting and stopping.

## Increased higher performance

### Strong and Stable Lower Frame

Reinforced box-section frame is all welded, low-stress, high-strength steel. It guarantees safety and resistance against external impact when driving on rough ground and working on wet sites through high tensile strength steel panels, with highly durable upper and lower rollers and track guards. Long undercarriage incorporates heavy duty excavator style components. X-leg type center frame is integrally welded for maximum strength and durability.



### Track Rail Guide & Adjusters

Durable track rail guides keep track links in place. Track adjustment is made easy with standard grease cylinder track adjusters and shock absorbing springs.

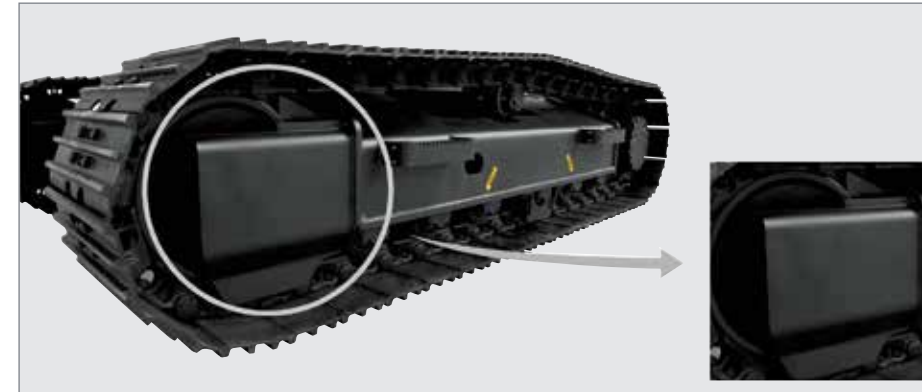

### Powerful and Preciser Swing Control

Improved shock absorbing characteristics make stopping a precise and smooth action



### Minimization of Shock and Vibration through Cab Mounting System

The application of Viscous Mounting to the cabin support provides the operator with a much improved ride. The operator work efficiency will increase as the shock and noise level in the cabin decreases.

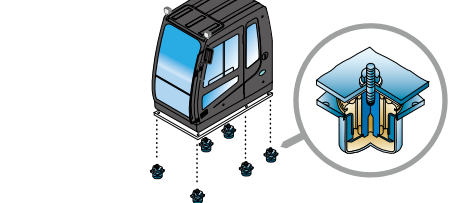

### Mitsubishi S4K-T ENGINE

The four cylinders turbo-charged Mitsubishi S4K-T engine is built for power, reliability and economy. This engine meets EPA tier II and EU stage II emission regulation.



### Reliability You Can Depend On

Mitsubishi S4K-T engine is an ideal solution for the toughest work environment. The engine is built from laser hardened cast iron cylinder block, eight balance, one-piece, forged crankshaft and heat resistant aluminum alloy pistons. This combination provides maximum strength, rigidity and low fuel and oil consumption.

The S4K-T engine is capable of reaching emission standards without electronic engine controls. You get a proven power plant that meets ecological concerns, without paying a premium for technology you don't need.

### Reinforced Bucket and Bucket Linkage

Sealed and adjustable bucket linkage provides less wear of pins and bushes as well as silent operation. The design includes bucket link durability and anti wear characteristics. Additional reinforcement plates on cutting edge section. Reinforced bucket is made with thicker steel and additional lateral plate.





# Robex 110D-7



Durability of structure proven through FEM(Finite Element Method) analysis and long term durability test.

Photo may include optional equipment

## Reliability & Serviceability



### Easy to maintain engine components

The cooling and preheating system are provided for optimum and immediate operation, guaranteeing longer life for the engine and hydraulic components. Servicing of the engine and hydraulics is considerably simplified due to total accessibility.



### Centralized Electric Control Box and Easy Change Air Cleaner Assembly

Electric control box and Air cleaner are centralized in one or the same compartment for easy service.



### Side Cover with Left & Right Swing Open Type

Easy access to vital components gives unrestricted view of component allows easy maintenance and repair.



### Large tool box for extra storage



### Highly efficient Hydraulic Pump

Pump output and Hydraulic tank capacity have been increased. A pilot pump has been installed resulting in improved control sensitivity.



## Engine

Model		Mitsubishi S4K-T	
Type			
		Water cooled, 4 cycle Diesel. 4 Cylinders in line, direct injection turbocharged and low emission	
Rated horse power	SAE	J1995(gross)	94HP(70kW) at 1,950rpm
		J1349(net)	84HP (63kW) at 1,950rpm
	DIN	6271/1(gross)	95PS(70kW) at 1,950rpm
		6271/1(net)	85PS (63kW) at 1,950rpm
Max. torque		37.9kgf.m(274 lbf.ft) at 1,400rpm	
Bore X stroke		102 x 130mm (4.0" x 5.1")	
Piston displacement		4,249cc (259 cu in)	
Batteries		2 x 12V x 80AH	
Starter motor		24V-5.0kW	
Alternator		24V- 50 Amp	

## Hydraulic system

Main pump	
Type	Two variable displacement piston pumps
Max. flow	2 x 112l/min ( 29.6US gpm/ 24.6UK gpm)
Sub-pump for pilot circuit	Gear pump
Hydraulic motors	
Travel	Two speed axial piston motor with brake valve and parking brake
Swing	Axial piston motor with automatic brake
Relief valve setting	
Implement circuits	330 kgf/cm2 (4,690psi)
Travel	330 kgf/cm2 (4,690 psi)
Power boost (boom, arm, bucket)	360 kgf/cm2 (5,120psi)
Swing circuit	240 kgf/cm2 (3,410psi)
Pilot circuit	35 kgf/cm2 (498psi)
Service valve	Installed
Hydraulic cylinders	
No. of cylinderbore x stroke	Boom : 2 - 95 x 1015mm (3.7" x 40.0")
	Arm : 1 - 110 x 1070mm (4.3" x 42.1")
	Bucket : 1 - 95 x 855mm (3.7" x 33.7")
	Blade : 2 - 100 x 240mm (3.9" x 9.4")

## Drives & Brakes

Drive method	Fully hydrostatic type
Drive motor	Axial piston motor, in-shoe design
Reduction system	Planetary reduction gear
Max. drawbar pull	11,000 kgf ( 24,250 lbf)
Max. travel speed(high) / (low)	5.5 km/hr( 3.4mph) / 3.4 km/hr ( 2.1mph)
Gradeability	35° (70%)
Parking brake	Multi wet disc

## Control

Pilot pressure operated joysticks and pedals with detachable lever provide almost effortless and fatigueless operation.

Pilot control	Two joysticks with one safety lever (LH) : Swing and arm (RH) : Boom and bucket (ISO)
Traveling and steering	Two levers and pedals
Engine throttle	Electric, Dial type
External lights	Two lights mounted on the boom, one under the battery box

## Swing system

Swing motor	Axial piston motor
Swing reduction	Planetary gear reduction
Swing bearing lubrication	Grease-bathed
Swing brake	Multi wet disc
Swing speed	13.0 rpm

## Coolant & Lubricant capacity

(Refilling)	liter	US gal	UK gal
Fuel tank	250	66.0	55.0
Engine coolant	24	6.3	5.3
Engine oil	17.5	4.6	3.8
Swing device	2.5	0.7	0.5
Final drive(each)	2.5	0.7	0.5
Hydraulic system(including tank)	180	47.6	39.6
Hydraulic tank	100	26.4	22.0

## Undercarriage

X-leg type center frame is integrally welded with reinforced box-section track frames. The undercarriage includes lubricated rollers, idlers, track adjusters with shock absorbing spring and sprockets, and track chain with double or triple grouser shoes.

Center frame	X - leg type
Track frame	Pentagonal box type
No. of shoes on each side	41
No. of carrier roller on each side	1
No. of track roller on each side	6
No. of rail guard on each side	1

## Operating weight (approximate)

Operating weight, including 4,300mm (14' 1") boom, 2,260m (7' 5") arm, SAE heaped 0.45m<sup>3</sup> (0.59yd<sup>3</sup>) backhoe bucket, lubricant, coolant, full fuel tank, hydraulic tank and the standard equipment.

## Major component weight

Upperstructure	3,300kg (7,280lb)
Counterweight	1,450kg (3,200lb)
Boom (with Arm cylinder)	950kg (2,090lb)

## Operating weight

Type	Shoes		Operating weight		Ground pressure	
	Width mm(in)		kg(lb)		kgf/cm2(psi)	
Triple grouser	※ 500 (20")	R110-7	11,200 (24,690)	0.39 (5.55)		
		R110-7	11,900 (26,230)	0.42 (5.97)		
	600 (24")	R110-7	11,500 (25,350)	0.34 (4.84)		
		R110D-7	12,200 (26,900)	0.36 (5.12)		
	700 (28")	R110D-7	11,800 (26,010)	0.30 (4.27)		
		R110D-7	12,500 (27,560)	0.31 (4.41)		

※ Standard equipment

## Buckets

SAE heaped m <sup>3</sup> (yd <sup>3</sup> )					
	0.30(0.39)	0.40(0.52)	※0.45(0.59)	0.50(0.65)	0.59(0.77)

Capacity m <sup>3</sup> (yd <sup>3</sup> )		Width mm (in)		Weight kg(lb)	Recommendation mm(ft.in)			
SAE heaped	CECE heaped	Without side cutters	With side cutters		Mono Boom	※ 4,300 (14' 1")		
					Arm	1,960 (6' 5")	※ 2,260 (7' 5")	2,810 (9' 3")
0.30 (0.39)	0.27 (0.35)	610 (24.0)	720 (28.3)	360 (790)	●	●	●	
0.40 (0.52)	0.36 (0.47)	760 (29.9)	870 (34.3)	410 (900)	●	●	●	
※0.45 (0.59)	0.40 (0.52)	830 (32.7)	940 (37.0)	430 (950)	●	●	■	
0.50 (0.65)	0.45 (0.59)	900 (35.4)	1,010 (39.8)	450 (990)	●	■	▲	
0.59 (0.77)	0.52 (0.68)	1,020 (40.2)	1,130 (44.5)	490 (1,080)	■	▲	-	

※ Standard backhoe bucket

● Applicable for materials with density of 2,000 kg / m<sup>3</sup> (3,370 lb / yd<sup>3</sup>) or less  
 ■ Applicable for materials with density of 1,600 kg / m<sup>3</sup> (2,700 lb / yd<sup>3</sup>) or less  
 ▲ Applicable for materials with density of 1,100 kg / m<sup>3</sup> (1,850 lb / yd<sup>3</sup>) or less

## Backhoe attachment

Boom and arms are of all-welded, low-stress, full-box section design.

4,300mm(14' 4") mono boom and 1,960mm(6' 5"), 2,260m (7' 5"), 2,810mm (9' 3") arm are available.

Buckets are all-welded, high-strength steel implements.

		
1,960mm(6' 5")	※2,260mm(7' 5")	2,810mm (9' 3")

## Digging force

Arm	Length	mm(ft.in)	1,960mm (6'5")	※ 2,260mm (7' 5")	2,810mm (9'3")	Remark
			Weight	kg(lb)	320(710)	
Bucket digging force	SAE	kN	78.5[85.6]	78.5[85.6]	78.5[85.6]	[ Power Boost ]:
		kgf	8,000[8,730]	8,000[8,730]	8,000[8,730]	
		lbf	17,640[19,240]	17,640[19,240]	17,640[19,240]	
	ISO	kN	90.2[98.4]	90.2[98.4]	90.2[98.4]	
		kgf	9,200[10,040]	9,200[10,040]	9,200[10,040]	
		lbf	20,280[22,120]	20,280[22,120]	20,280[22,120]	
Arm crowd force	SAE	kN	60.2[65.7]	55.7[60.8]	48.1[52.4]	
		kgf	6,140[6,700]	5,680[6,200]	4,900[5,350]	
		lbf	13,540[14,770]	12,520[13,660]	10,800[11,780]	
	ISO	kN	62.9[68.6]	58.1[63.3]	49.7[54.2]	
		kgf	6,410[6,990]	5,920[6,460]	5,070[5,530]	
		lbf	14,130[15,410]	13,050[14,240]	11,180[12,200]	

※ Standard equipment



# Dimensions & Working ranged

## Dimensions R110-7

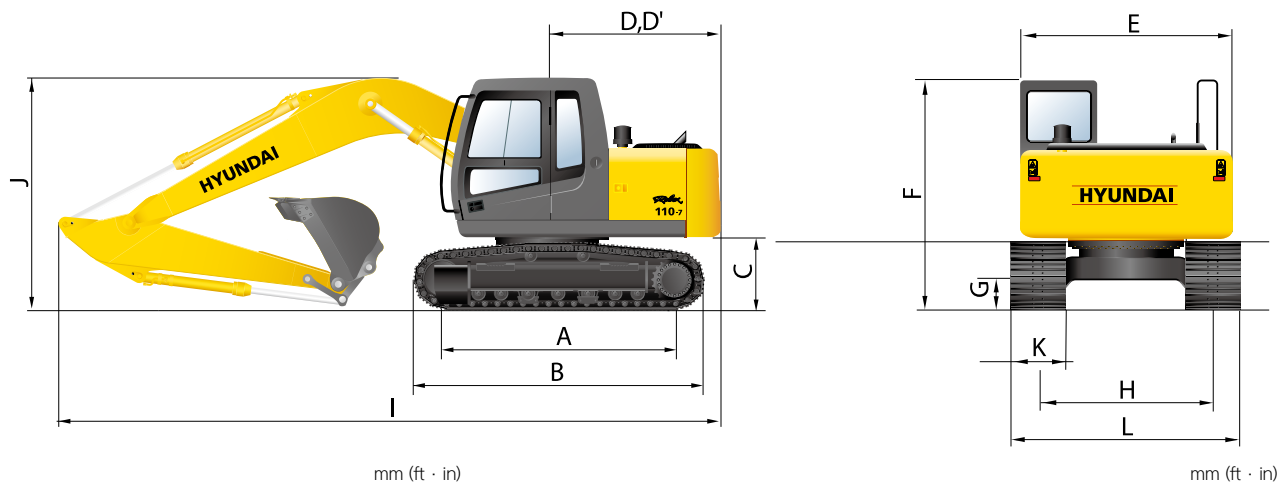

Description	R110-7	
A	Tumbler distance	2,610 (8'7")
B	Overall length of crawler	3,340 (10'11")
C	Ground clearance of counterweight	900 (2'11")
D	Tail swing radius	2,130 (7'0")
D'	Rear-end length	2,110 (6'11")
E	Overall width of upperstructure	2,475 (8'1")
F	Overall height of cabin	2,800 (9'2")
G	Min. ground clearance	440 (1'5")
H	Track gauge	1,990 (6'6")

Description	R110-7			
Boom length	※4,300 (14' 1") Mono boom			
Arm length	1,960 (6' 5")	※2,260 (7' 5")	2,810 (9' 3")	
I	Overall length	7,240 (23' 9")	7,270 (23' 10")	7,230 (23' 9")
J	Overall height of boom	2,550 (8' 4")	2,720 (8' 11")	3,060 (10' 0")
K	Track shoe width	500 (20")	600 (24")	700 (28")
L	Overall width	2,490 (8' 2")	2,590 (8' 6")	2,690 (8' 10")

## Dimensions R110D-7

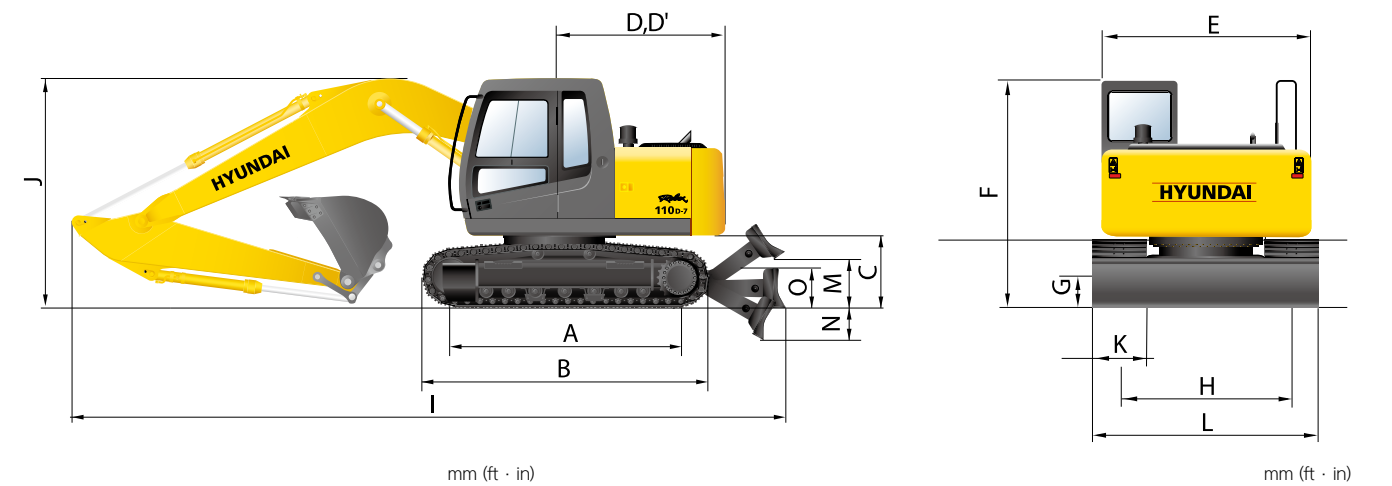

Description	R110D-7	
A	Tumbler distance	2,610 (8'7")
B	Overall length of crawler	3,340 (10'11")
C	Ground clearance of counterweight	900 (2'11")
D	Tail swing radius	2,130 (7'0")
D'	Rear-end length	2,110 (6'11")
E	Overall width of upperstructure	2,475 (8'1")
F	Overall height of cabin	2,800 (9'2")
G	Min. ground clearance	440 (1'5")
H	Track gauge	1,990 (6'6")
M	Ground Clearance of blade up	500 (1' 8")
N	Depth of blade down	520 (1' 8")

Description	R110D-7			
O	Height of blade	550 (1' 10")		
	Width of blade	2,500 (8' 2")		
Boom length	※4,300 (14' 1") Mono boom			
Arm length	1,960 (6' 5")	※2,260 (7' 5")	2,810 (9' 3")	
I	Overall length	7,620 (25' 0")	7,650 (25' 1")	7,610 (25' 0")
J	Overall height of boom	2,550 (8' 4")	2,720 (8' 11")	3,060 (10' 0")
K	Track shoe width	500 (20")	600 (24")	700 (28")
L	Overall width	2,490 (8' 2")	2,590 (8' 6")	2,690 (8' 10")

## Working ranges R110-7

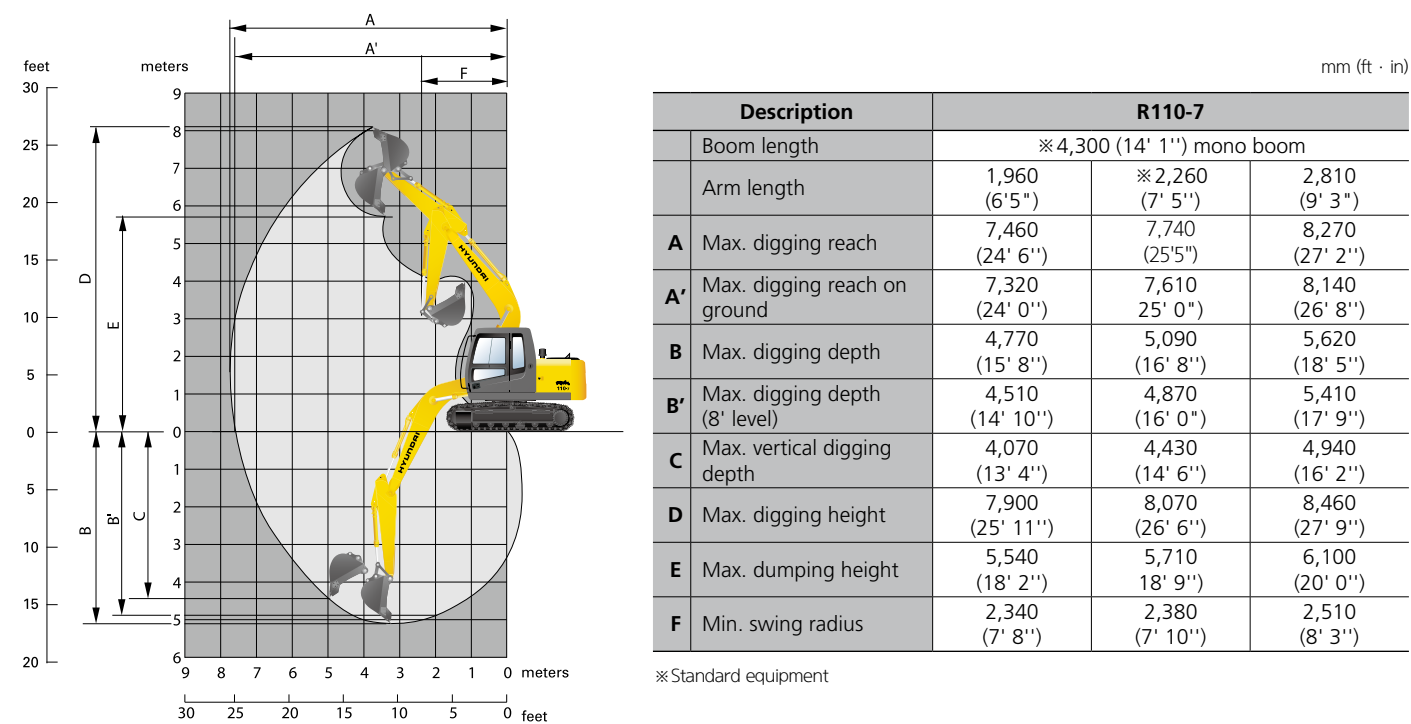

## Working ranges R110D-7

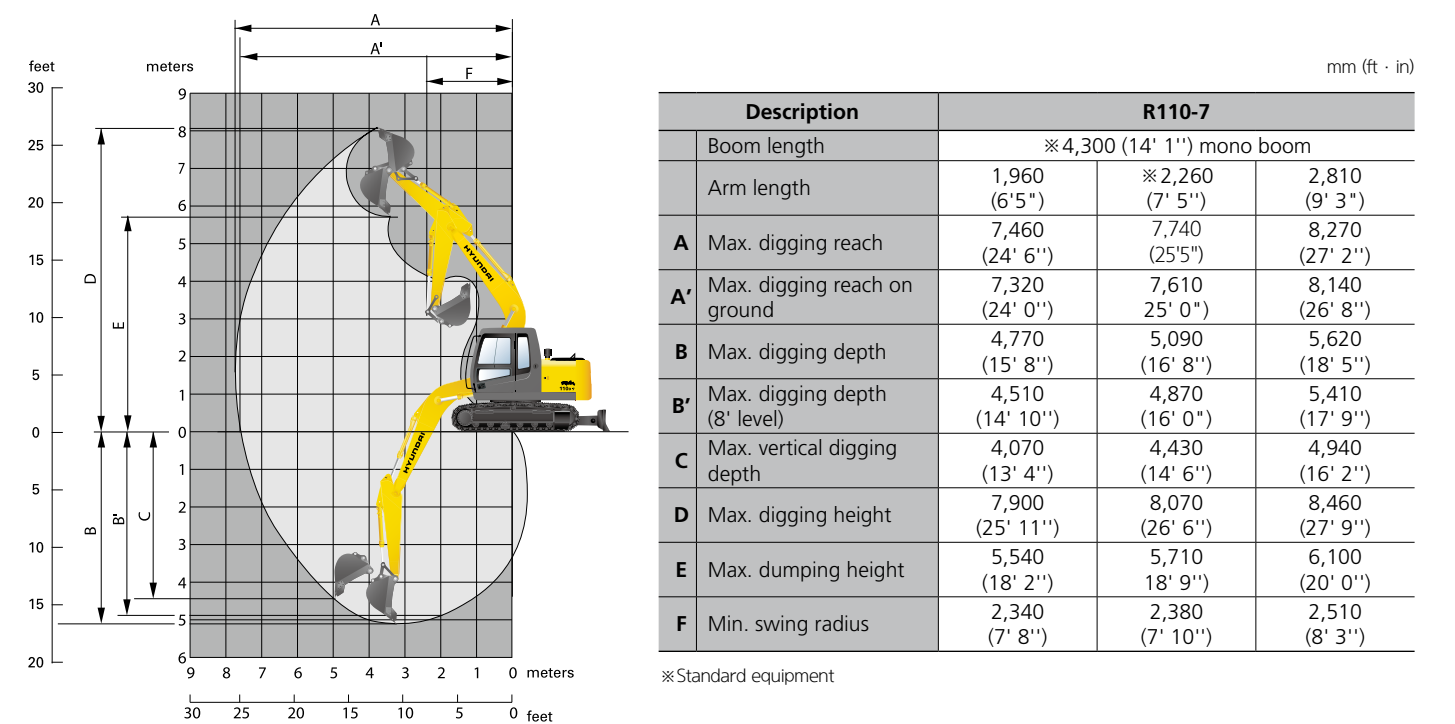



# Dimensions & Working ranged

## ⚙️ Lifting capacities R110-7

📏 Rating over-front   📏 Rating over-side or 360 degree

• Boom: 4.3 m (14' 1") • Arm: 2.26 m (7' 5") • Bucket: 0.45 m<sup>3</sup> (0.59yd<sup>3</sup>) SAE heaped • Shoe : 500mm(20") triple grouser with 1,450kg(3,200 lb) CWT

Load Point height m(ft)	Load radius								At max. reach			
	1.5m (5.0ft)		3.0m (10.0ft)		4.5m (15.0ft)		6.0m (20.0ft)		Capacity		Reach	
	📏	📏	📏	📏	📏	📏	📏	📏	📏	📏	m (ft)	
6.0m	kg					*1,750	*1,750			*1,750	1,560	5.99
20.0ft	lb					*3,860	*3,860			*3,860	3,440	(19.7)
4.5m	kg					*1,790	*1,790	*1,530	1,490	1,520	1,130	6.92
15.0ft	lb					*3,950	*3,950	*3,370	3,280	3,350	2,490	(22.7)
3.0m	kg			*2,820	*2,820	*2,270	*2,270	1,940	1,450	1,300	940	7.38
10.0ft	lb			*6,220	*6,220	*5,000	*5,000	4,280	3,200	2,870	2,070	(24.2)
1.5m	kg			*4,700	4,370	*2,970	2,250	1,840	1,360	1,240	880	7.46
5.0ft	lb			*10,360	9,630	*6,550	4,960	4,060	3,000	2,730	1,940	(24.5)
Ground	kg			5,660	3,950	2,830	2,060	1,760	1,280	1,300	930	7.18
Line	lb			12,480	8,710	6,240	4,540	3,880	2,820	2,870	2,050	(23.6)
-1.5m	kg	*5,580	*5,580	5,550	3,850	2,740	1,980	1,720	1,240	1,560	1,130	6.49
-5.0ft	lb	*12,300	*12,300	12,240	8,490	6,040	4,370	3,790	2,730	3,440	2,490	(21.3)
-3.0m	kg	*8,530	*8,530	*5,440	3,930	2,770	2,010			*2,270	1,730	5.17
-10.0ft	lb	*18,810	*18,810	*11,990	8,660	6,110	4,430			*5,000	3,810	(17.0)

• Boom: 4.3 m (14' 1") • Arm: 1.96 m (6' 5") • Bucket: 0.45 m<sup>3</sup> (0.59yd<sup>3</sup>) SAE heaped • Shoe : 500mm(20") triple grouser with 1,450kg(3,200 lb) CWT

Load Point height m(ft)	Load radius								At max. reach			
	1.5m (5.0ft)		3.0m (10.0ft)		4.5m (15.0ft)		6.0m (20.0ft)		Capacity		Reach	
	📏	📏	📏	📏	📏	📏	📏	📏	📏	📏	m (ft)	
6.0m	kg					*1,770	*1,770			*1,820	1,710	5.62
20.0ft	lb					*3,900	*3,900			*4,010	3,770	(18.4)
4.5m	kg					*1,950	*1,950			1,610	1,180	6.62
15.0ft	lb					*4,300	*4,300			3,550	2,600	(21.7)
3.0m	kg			*3,160	*3,160	*2,410	2,390	1,870	1,380	1,350	970	7.10
10.0ft	lb			*6,970	*6,970	*5,310	5,270	4,120	3,040	2,980	2,140	(23.3)
1.5m	kg			*4,940	4,150	2,930	2,150	1,780	1,290	1,280	910	7.18
5.0ft	lb			*10,890	9,150	6,460	4,740	3,920	2,840	2,820	2,010	(23.6)
Ground	kg			5,490	3,800	2,740	1,980	1,700	1,220	1,360	960	6.89
Line	lb			12,100	8,380	6,040	4,370	3,750	2,690	3,000	2,120	(22.6)
-1.5m	kg	*6,090	*6,090	5,440	3,750	2,670	1,910	1,720		1,670	1,200	6.15
-5.0ft	lb	*13,430	*13,430	11,990	8,270	5,890	4,210	3,790		3,680	2,650	(20.2)
-3.0m	kg	*9,180	*9,180	*5,080	3,880	2,750	1,980					
-10.0ft	lb	*20,240	*20,240	*11,200	8,550	6,060	4,370					

• Boom: 4.3 m (14' 1") • Arm: 2.81 m (9' 3") • Bucket: 0.45 m<sup>3</sup> (0.59yd<sup>3</sup>) SAE heaped • Shoe : 500mm(20") triple grouser with 1,450kg(3,200 lb) CWT

Load Point height m(ft)	Load radius								At max. reach			
	1.5m (5.0ft)		3.0m (10.0ft)		4.5m (15.0ft)		6.0m (20.0ft)		Capacity		Reach	
	📏	📏	📏	📏	📏	📏	📏	📏	📏	📏	m (ft)	
6.0m	kg									*1,570	1,290	6.66
20.0ft	lb									*3,640	2,840	(21.9)
4.5m	kg							*1,830	1,500	1,330	980	7.50
15.0ft	lb							*4,030	3,310	2,930	2,160	(24.6)
3.0m	kg					*1,920	*1,920	*1,640	1,570	1,160	830	7.92
10.0ft	lb					*4,230	*4,230	*3,620	3,460	2,560	1,830	(23.3)
1.5m	kg			*4,050	*4,050	*2,690	2,340	1,890	1,410	1,100	780	7.99
5.0ft	lb			*8,930	*8,930	*5,930	5,160	4,710	3,110	2,430	1,720	(26.2)
Ground	kg	*4,960	*4,960	*5,580	4,110	2,900	2,130	1,790	1,310	1,150	820	7.74
Line	lb	*10,930	*10,930	*12,300	9,060	6,390	4,700	3,950	2,890	2,540	1,810	(25.4)
-1.5m	kg	*3,230	*3,230	5,620	3,920	2,770	2,010	1,730	1,250	1,330	960	7.11
-5.0ft	lb	*7,120	*7,120	12,390	8,640	6,110	4,430	3,810	2,760	2,930	2,120	(23.2)
-3.0m	kg	*7,230	*7,230	5,630	3,930	2,760	2,000			1,830	1,350	5.96
-10.0ft	lb	*15,940	*15,940	12,410	8,660	6,080	4,410			4,030	2,980	(19.6)
-4.5m	kg			*4,480	4,100							
-15.0ft	lb			*9,880	9,040							

NOTES 1. Lifting capacity is based on SAE J1097, ISO 10567. 2. Lifting capacity of the Robex Series does not exceed 75% of tipping load with the machine on firm, level ground or 87% of full hydraulic capacity. 3. The load point is a hook (standard equipment) located on the back of the bucket. 4. (\*) indicates load limited by hydraulic capacity.

## ⚙️ Lifting capacities R110D-7

📏 Rating over-front   📏 Rating over-side or 360 degree

• Boom: 4.3 m (14' 1") • Arm: 2.26 m (7' 5") • Bucket: 0.45 m<sup>3</sup> (0.59yd<sup>3</sup>) SAE heaped • Shoe : 500mm(20") triple grouser with 1,450kg(3,200 lb) CWT

Load Point height m(ft)	Load radius								At max. reach				
	1.5m (5.0ft)		3.0m (10.0ft)		4.5m (15.0ft)		6.0m (20.0ft)		Capacity		Reach		
	📏	📏	📏	📏	📏	📏	📏	📏	📏	📏	m (ft)		
6.0m	kg					*1,750	*1,750			*1,750	*1,750	5.99	
20.0ft	lb					*3,860	*3,860			*3,860	*3,860	(19.7)	
4.5m	kg					*1,790	*1,790	*1,530	*1,530	1,650	1,340	6.92	
15.0ft	lb					*3,950	*3,950	*3,370	*3,370	3,640	2,950	(22.7)	
3.0m	kg						*2,820	*2,820	*2,270	*2,270	*2,060	1,710	7.38
10.0ft	lb						*6,220	*6,220	*5,000	*5,000	*4,540	3,770	(24.2)
1.5m	kg						*4,700	*4,700	*2,970	2,650	2,000	1,620	7.46
5.0ft	lb						*10,360	*10,360	*6,550	5,840	4,410	3,570	(24.5)
Ground	kg						*5,860	4,750	3,060	2,460	1,910	1,540	7.18
Line	lb						*12,920	10,470	6,750	5,420	4,210	3,400	(23.6)
-1.5m	kg	*5,580	*5,580	5,980	4,640	2,970	2,370	1,880	1,500	1,700	1,360	6.49	
-5.0ft	lb	*12,300	*12,300	13,180	10,230	6,550	5,220	4,140	3,310	3,750	3,000	(21.3)	
-3.0m	kg	*8,530	*8,530	*5,440	4,720	3,000	2,400			*2,270	2,050	5.17	
-10.0ft	lb	*18,810	*18,810	*11,990	10,410	6,610	5,290			*5,000	4,520	(17.0)	

• Boom: 4.3 m (14' 1") • Arm: 1.96 m (6' 5") • Bucket: 0.45 m<sup>3</sup> (0.59yd<sup>3</sup>) SAE heaped • Shoe : 500mm(20") triple grouser with 1,450kg(3,200 lb) CWT

Load Point height m(ft)	Load radius								At max. reach				
	1.5m (5.0ft)		3.0m (10.0ft)		4.5m (15.0ft)		6.0m (20.0ft)		Capacity		Reach		
	📏	📏	📏	📏	📏	📏	📏	📏	📏	📏	m (ft)		
6.0m	kg					*1,770	*1,770			*1,820	*1,820	5.62	
20.0ft	lb					*3,900	*3,900			*4,010	*4,010	(18.4)	
4.5m	kg					*1,950	*1,950			1,750	1,420	6.62	
15.0ft	lb					*4,300	*4,300			3,860	3,130	(21.7)	
3.0m	kg						*3,160	*3,160	*2,410	*2,410	2,020	1,640	7.10
10.0ft	lb						*6,970	*6,970	*5,310	*5,310	4,450	3,620	(23.3)
1.5m	kg						*4,940	*4,940	*3,060	2,550	1,940	1,560	7.18
5.0ft	lb						*10,890	*10,890	*6,750	5,620	4,280	3,440	(23.6)
Ground	kg						*5,870	4,580	6,970	2,370	1,860	1,480	6.89
Line	lb						*12,940	10,100	6,550	5,220	4,100	3,260	(22.6)
-1.5m	kg	*6,090	*6,090	*5,860	4,540	2,900	2,310						
-5.0ft	lb	*13,430	*13,430	*12,920	10,010	6,390	5,090						
-3.0m	kg	*9,180	*9,180	*5,080	4,670	2,980	2,380						
-10.0ft	lb	*20,240	*20,240	*11,200	10,300	6,570	5,250						

• Boom: 4.3 m (14' 1") • Arm: 2.81 m (9' 3") • Bucket: 0.45 m<sup>3</sup> (0.59yd<sup>3</sup>) SAE heaped • Shoe : 500mm(20") triple grouser with 1,450kg(3,200 lb) CWT

Load Point height m(ft)	Load radius								At max. reach			
	1.5m (5.0ft)		3.0m (10.0ft)		4.5m (15.0ft)		6.0m (20.0ft)		Capacity		Reach	
	📏	📏	📏	📏	📏	📏	📏	📏	📏	📏	m (ft)	
6.0m	kg									*1,570	1,520	6.66
20.0ft	lb									*3,640	3,350	(21.9)
4.5m	kg											
15.0ft	lb											
3.0m	kg									*1,920	*1,920	7.92